



SUBMITTAL DATA

CAS18HP230V1R32AH
18000 BTU/H Cassette Heat Pump System

| | | |
|--|---|---|
| Job Name | Location | Date |
| Purchaser | Engineer | |
| Submitted to | For | |
| Unit Designation | Schedule No. | |
|  YBE1FB5F |  CAS18HP230V1R32AH |  XE72-44/E |

GENERAL FEATURES

- AHRI Certificate: 215417457 (Vireo R32), 215417450 (Envo R32), 215416024 (Sapphire R32)
- High Efficiency DC Inverter Technology
- Compact and Quiet Design
- 4 - Way Discharge Air
- Swing Louver Control
- Internal Condensate Drain Pump
- Wireless Remote with LCD Display Included
- XE72-44/E Wired Controller Included
- Low Ambient Cooling and Heating
- (Indoor and Outdoor) Copper Tube / Aluminum Fin
- Blue Colored Fin - 500 Hrs Salt Spray Tested
- New R32 Refrigerant with Refrigerant Sensor

SPECIFICATIONS, FEATURES & FUNCTION SUMMARY

| INDOOR MODEL | | CAS18HP230V1R32AH | | | |
|---|-------------------|-------------------|---|--------------------------------|--------------------------------|
| System Type | | HEAT PUMP | | | |
| Outdoor Model | | VIR18HP230V1R32AO | ENV18HP230V1R32AO | SAP18HP230V1R32AO | |
| SYSTEM PERFORMANCE | | | | | |
| Cooling | Min - Max | Btu/h | 5,100 - 23,200 | 5,100 - 23,200 | 5,100 - 23,200 |
| | Capacity @95°F | Btu/h | 18,000 | 18,000 | 18,000 |
| Heating | Min - Max | Btu/h | 5,800 - 23,500 | 5,800 - 23,500 | 5,800 - 23,500 |
| | Capacity @47°F | Btu/h | 18,000 | 18,000 | 18,000 |
| | Capacity @17°F | Btu/h | 12,500 | 12,500 | 12,500 |
| | Capacity Max @5°F | Btu/h | 12,600 | 7,600 | 13,500 |
| SEER2 | | | 21.0 | 21.0 | 23.0 |
| EER2 | | | 10.9 | 10.9 | 10.75 |
| HSPF2 | | | 9.0 | 9.0 | 9.2 |
| COP @5°F | | | 1.80 | 1.80 | 1.80 |
| Cooling Temperature Range | | °F | | -20 - 122 | |
| Heating Temperature Range | | °F | | -22 - 86 | |
| Refrigerant Type | | | | R32 | |
| INDOOR UNIT | | CAS18HP230V1R32AH | | | |
| Air flow (Min-Max) | | CFM | 206 - 383 | | |
| Sound Pressure Level (Min - Max) | | dB(A) | 30 - 44 | | |
| Dehumidification | | pt/hr | 3.8 | | |
| External Dimensions (L x D x H) | | in | 22-7/16 x 22-7/16 x 10-7/16 | | |
| Package Dimension (L x W x H) | | in | 27-31/64 x 25-45/64 x 11-39/64 | | |
| Net Weight | | lbs | 37.5 | | |
| Gross Weight | | lbs | 48.5 | | |
| CASSETTE GRILLE (REQUIRED) | | GREETF05 | | | |
| Grille Dimension (L x D x H) | | in | 24-13/32 x 24-13/32 x 1-7/8 | | |
| Package Dimension (L x W x H) | | in | 27-19/32 x 27-19/32 x 4-59/64 | | |
| Weight (Net / Gross) | | lbs | 6.6 / 9.9 | | |
| OUTDOOR UNIT | | VIR18HP230V1R32AO | ENV18HP230V1R32AO | SAP18HP230V1R32AO | |
| Sound Pressure Level | | dB(A) | 59 | 59 | 59 |
| External Dimensions (L x D x H) | | in | 37-23/32 x 15-53/64 x 25-63/64 | 37-23/32 x 15-53/64 x 25-63/64 | 37-23/32 x 15-53/64 x 25-63/64 |
| Package Dimension (L x W x H) | | in | 40-5/8 x 17-61/64 x 29-1/64 | 40-5/8 x 17-61/64 x 29-1/64 | 40-5/8 x 17-61/64 x 29-1/64 |
| Net Weight | | lbs | 94.8 | 94.8 | 94.8 |
| Gross Weight | | lbs | 104.7 | 104.7 | 104.7 |
| REFRIGERANT PIPING | | | | | |
| Refrigerant Charge - R410A | | oz | 40.6 | 40.6 | 47.6 |
| Additional Charge | | oz/ft | 0.2 | 0.2 | 0.4 |
| Line Set Sized by Indoor Unit (Liquid - Gas) | | in | | 1/4 - 1/2 | |
| Line Set Size (Liquid - Gas) - Flared Connections | | in | 1/4 - 1/2 | 1/4 - 1/2 | 1/4 - 5/8 |
| Pre-Charge Length | | ft | | 25 | |
| Pipe Length (Min - Max) | | ft | 10 - 131 | 10 - 131 | 10 - 131 |
| Max. Pipe Elevation | | ft | 82 | 82 | 82 |
| ELECTRICAL | | | | | |
| Power Supply | | | 208-230V / 1Ph / 60Hz (Powered by the Outdoor Unit) | | |
| Voltage Range (Min - Max) | | VAC | 187 - 253 | | |
| Rated Current - Cooling | | A | 11.5 | 5.9 | 12.5 |
| Rated Current - Heating | | A | 11.5 | 7.8 | 16 |
| MCA | | A | 16 | 11 | 20 |
| MOCP | | A | 20 | 15 | 25 |
| Suggested Breaker Size | | A | 20 | 15 | 20 |
| Main Power Wire Size | | AWG | Per Local Code | | |
| Interconnecting Wire Size | | AWG | 14 / 4 | | |

FEATURES & FUNCTIONS SUMMARY

SYSTEM FEATURES

| | |
|---|---------------------------------------|
| Inverter Type | G20 with Field Oriented control (FOC) |
| Ultra Low Frequency Torque Control | Yes |
| Power Factor Correction | Yes |
| Compressor Type - Inverter | High Efficiency Rotary |
| Basepan With Electric Heater | Yes |
| Indoor & Outdoor Fin Coating (Blue Fin) | Yes |
| Intelligent Defrosting | Yes |
| Intelligent Preheating | Yes |
| Low Voltage Startup | Yes |
| Memory/Power Failure Recovery | Yes |
| Self Diagnosis | Yes |
| Wired Controller Interface | Yes |
| WiFi Included | No |
| Indoor Fan Type | Centrifugal |
| Multi Fan Speeds | 4 Speeds |
| Indoor Unit Display | Yes |
| Auxiliary Electrical Heater | No |
| Ventilation (Outdoor Air) | Yes |

REMOTE CONTROLLER FUNCTIONS

| | |
|---|-----|
| Auto Mode | Yes |
| Auto Fan | Yes |
| Auto Swing (Horizontal Auto Swing) | No |
| Auto Swing - 180° (Vertical Auto Swing) | Yes |
| Clock | Yes |
| Dry Mode | Yes |
| Dry Anti-Mildew (X-Fan) Mode | Yes |
| Energy Saving Mode | Yes |
| Dirty Filter Alert | No |
| Fan Speed Control (7 Speeds) | Yes |
| I Feel Function | Yes |
| Privacy Lock | Yes |
| Quiet Mode | Yes |
| Room Temperature Display | No |
| Sleep Mode | Yes |
| 3 Sleep Mode Options | Yes |
| Timer Mode | Yes |
| Turbo Mode | Yes |
| Display On/Off Control | Yes |
| Freeze Guard Mode | Yes |
| Power Failure Mode | Yes |

NOTE:

Please check the Multi-zone submittals for Non-Ducted or Mixed Performance table.

DIMENSIONS

INDOOR UNIT

Unit: inch

| CAS18HP230V1R32AH | |
|-------------------|----------|
| DIMENSIONS | |
| A | 24 13/32 |
| B | 22 53/64 |
| C | 22 7/16 |
| D | 19 7/8 |
| E | 21 21/32 |
| F | 10 7/16 |
| G | 5 33/64 |
| H | 20 55/64 |
| I | 20 55/64 |

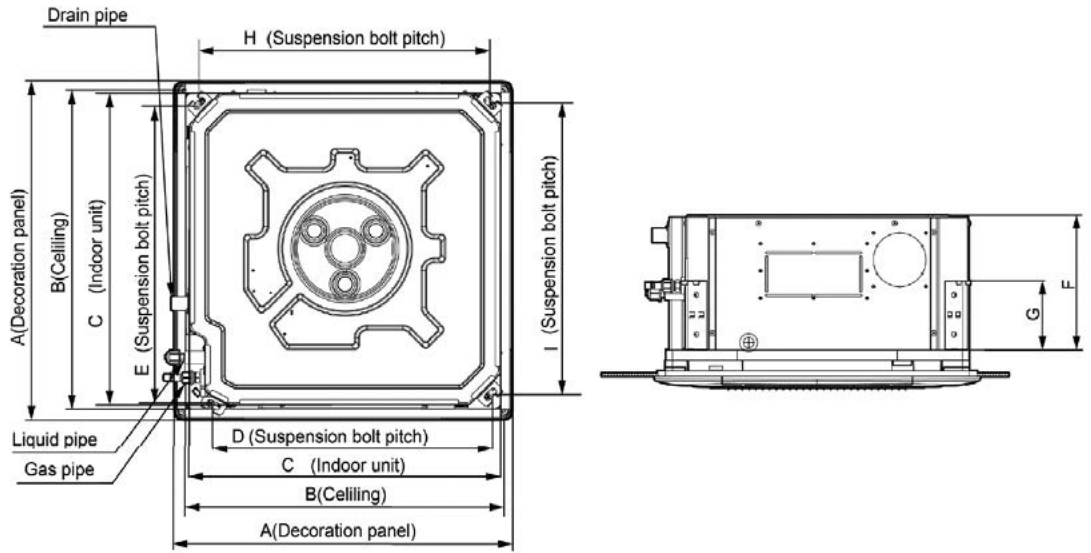

OUTDOOR UNIT

Unit: inch

| VIR18HP230V1R32AO | |
|-------------------|----------|
| DIMENSIONS | |
| A | 35 |
| B | 37 23/32 |
| C | 25 63/64 |
| D | 13 25/64 |
| E | 15 53/64 |
| F | 22 7/16 |
| G | 14 39/64 |

| ENV18HP230V1R32AO | |
|-------------------|----------|
| DIMENSIONS | |
| A | 35 |
| B | 37 23/32 |
| C | 25 63/64 |
| D | 13 25/64 |
| E | 15 53/64 |
| F | 22 7/16 |
| G | 14 39/64 |

| SAP18HP230V1R32AO | |
|-------------------|----------|
| DIMENSIONS | |
| A | 35 |
| B | 37 23/32 |
| C | 25 63/64 |
| D | 13 25/64 |
| E | 15 53/64 |
| F | 22 7/16 |
| G | 14 39/64 |

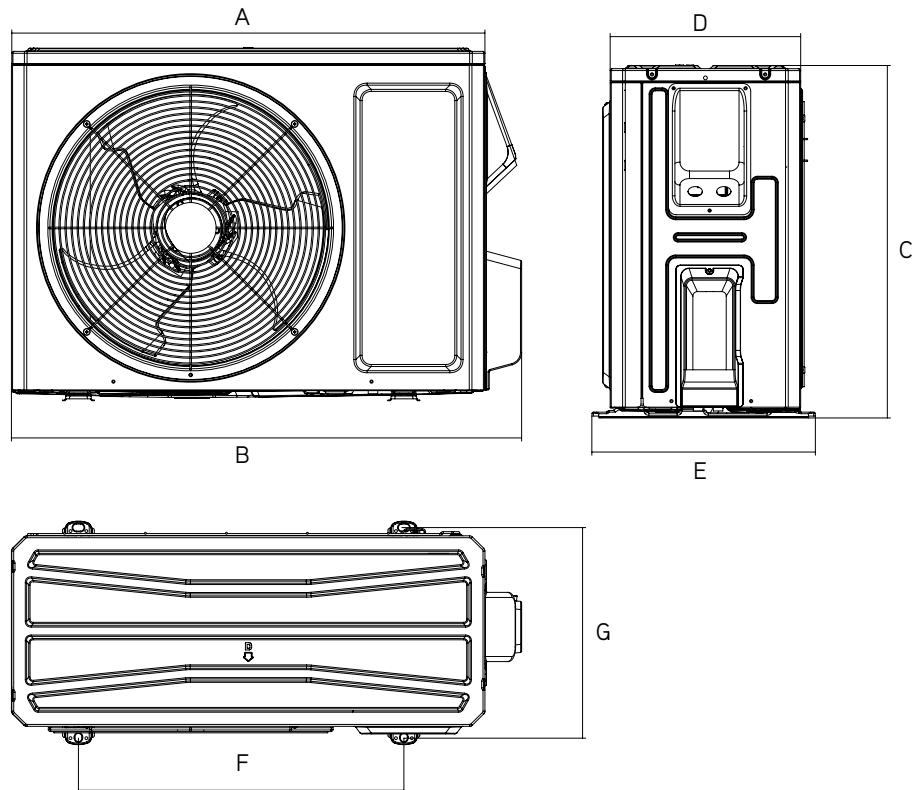

CLEARANCES

INDOOR UNIT

Minimum clearance

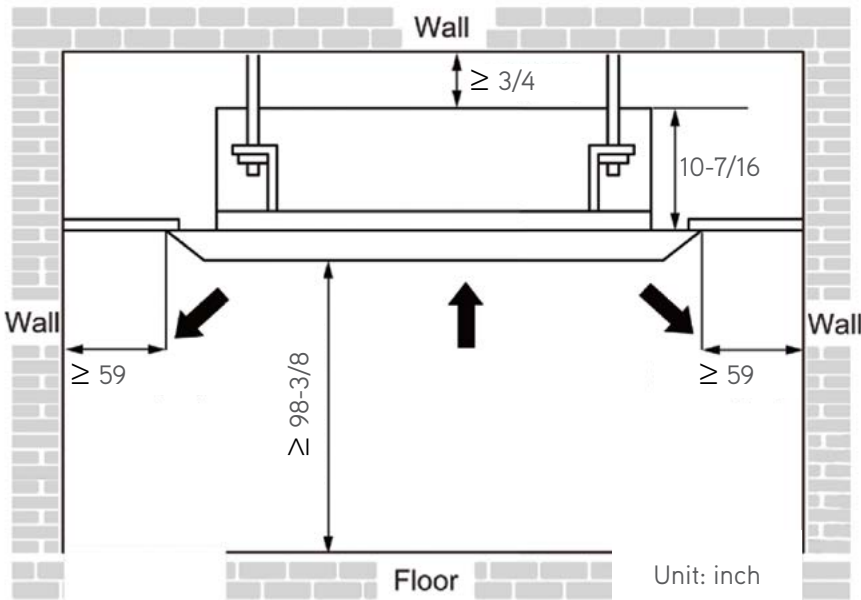

OUTDOOR UNIT

Minimum clearance

NOTE:
If bottom of the unit is free of airflow obstructions similar to the mounting bracket figure, the clearance to the wall on the back can be reduced to 3 inches.

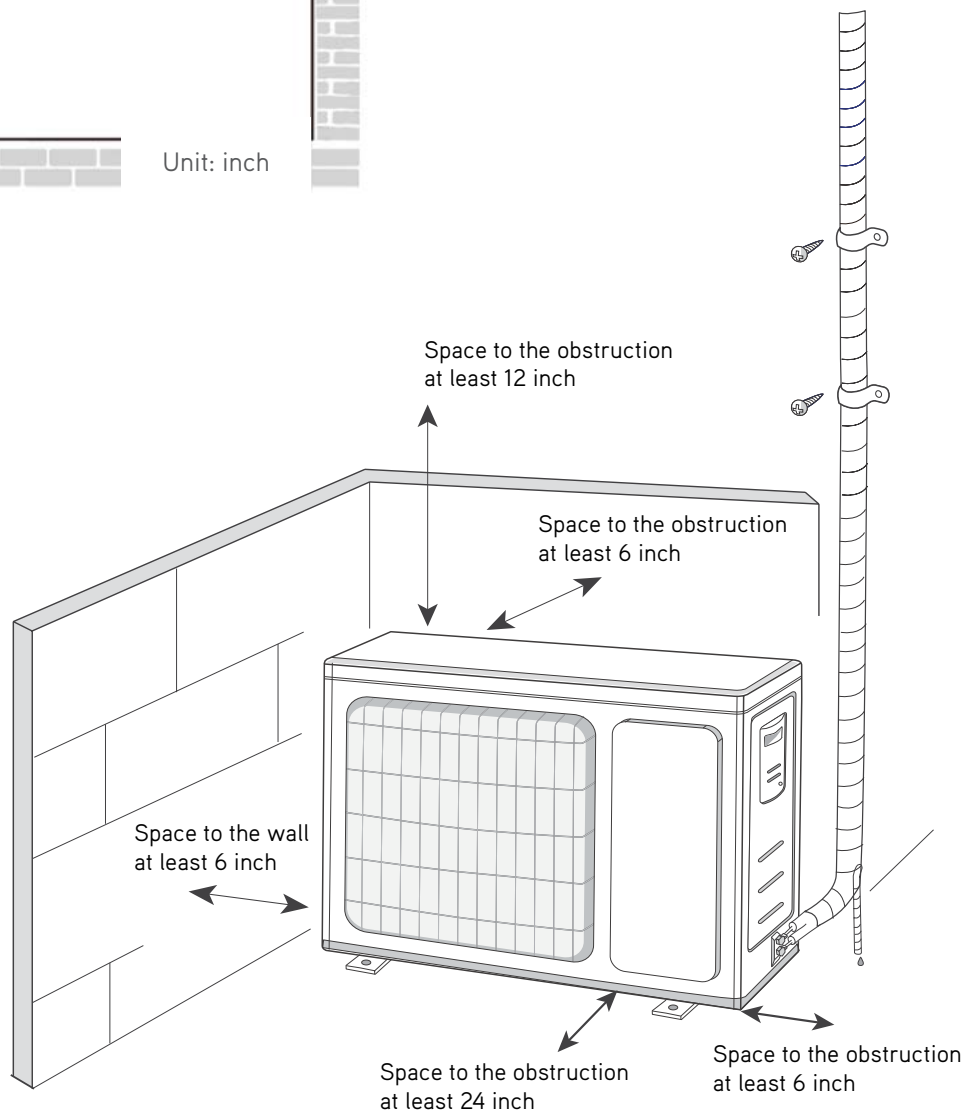

Specifications are subject to change without notice. Manufacturer reserves the right to discontinue or modify specifications or designs without notice or without incurring obligations. All Rights reserved.