



SUBMITTAL DATA

FLR36HP230V1R32AH
36000 BTU/H Floor Ceiling Heat Pump System

Job Name	Location	Date
Purchaser	Engineer	
Submitted to	For	
Unit Designation	Schedule No.	

		
YBE1FB5F	FLR36HP230V1R32AH	XE72-44/E

GENERAL FEATURES

- AHRI Certificate: [215415561 \(Livo R32 36Btu/h\)](#)
- Quiet Operation and Multi-Speed Fan
- Floor Stand or Ceiling Mount
- Multi-Directional Air Flow
- Wireless Remote with LCD Display Included
- XE72-44/E Wired Controller Included
- Low Ambient Cooling and Heating
- (Indoor and Outdoor) Copper Tube / Aluminum Fin
- Blue Colored Fin - 500 Hrs Salt Spray Tested
- New R32 Refrigerant with Refrigerant Sensor

SPECIFICATIONS, FEATURES & FUNCTION SUMMARY

INDOOR MODEL			FLR36HP230V1R32AH	FEATURES & FUNCTIONS SUMMARY		
System Type			HEAT PUMP			
Outdoor Model			LIV36HP230V1R32AO			
SYSTEM PERFORMANCE				SYSTEM FEATURES		
Cooling	Min - Max	Btu/h	21,736 - 45,050		Inverter Type	G20 with Field Oriented control (FOC)
	Capacity @95°F	Btu/h	33,600		Ultra Low Frequency Torque Control	Yes
	Min - Max	Btu/h	18,396 - 42,729		Power Factor Correction	Yes
Heating	Capacity @47°F	Btu/h	34,000		Compressor Type - Inverter	High Efficiency Rotary
	Capacity @17°F	Btu/h	18,800		Basepan With Electric Heater	Yes
	Capacity Max @5°F	Btu/h	22,000		Indoor & Outdoor Fin Coating (Blue Fin)	Yes
SEER2			21.0		Intelligent Defrosting	Yes
EER2			11.25		Intelligent Preheating	Yes
HSPF2			8.5		Low Voltage Startup	Yes
COP @5°F			1.80		Memory/Power Failure Recovery	Yes
Cooling Temperature Range		°F	0 - 118		Self Diagnosis	Yes
Heating Temperature Range		°F	-13 - 75		Wired Controller Interface	Yes
Refrigerant Type			R32		WiFi Included	No
INDOOR UNIT			FLR36HP230V1R32AH	Indoor Fan Type		Centrifugal
Air flow (Min-Max)		CFM	895 - 1236		Multi Fan Speeds	4 Speeds
Sound Pressure Level (Min - Max)		dB(A)	44 - 54		Indoor Unit Display	Yes
Dehumidification		pt/hr	7.82		Auxiliary Electrical Heater	No
External Dimensions (L x D x H)		in	61-13/16 x 26-3/16 x 9-1/4		Ventilation (Outdoor Air)	Yes
Package Dimension (L x W x H)		in	68-5/64 x 30-5/16 x 11-13/16		REMOTE CONTROLLER FUNCTIONS	
Net Weight		lbs	92.6		Auto Mode	Yes
Gross Weight		lbs	108.0		Auto Fan	Yes
OUTDOOR UNIT			LIV36HP230V1R32AO	Auto Swing (Horizontal Auto Swing)		No
Sound Pressure Level		dB(A)	62		Auto Swing - 180° (Vertical Auto Swing)	Yes
External Dimensions (L x D x H)		in	39-3/8 x 15-13/16 x 29-3/8		Clock	Yes
Package Dimension (L x W x H)		in	42-33/64 x 19-1/64 x 31-57/64		Dry Mode	Yes
Net Weight		lbs	122.4		Dry Anti-Mildew (X-Fan) Mode	Yes
Gross Weight		lbs	133.4		Energy Saving Mode	Yes
REFRIGERANT PIPING					Dirty Filter Alert	No
Refrigerant Charge - R410A		oz	56.4		Fan Speed Control (7 Speeds)	Yes
Additional Charge		oz/ft	0.4		I Feel Function	Yes
Line Set Sized by Indoor Unit (Liquid - Gas)		in	1/4 - 5/8		Privacy Lock	Yes
Line Set Size (Liquid - Gas) - Flared Connections		in	1/4 - 5/8		Quiet Mode	Yes
Pre-Charge Length		ft	25		Room Temperature Display	No
Pipe Length (Min - Max)		ft	10 - 131		Sleep Mode	Yes
Max. Pipe Elevation		ft	82		3 Sleep Mode Options	Yes
ELECTRICAL					Timer Mode	Yes
Power Supply		208-230V / 1Ph / 60Hz (Powered by the Outdoor Unit)		Turbo Mode		Yes
Voltage Range (Min - Max)		VAC	187 - 253		Display On/Off Control	Yes
Rated Current - Cooling		A	20		Freeze Guard Mode	Yes
Rated Current - Heating		A	20		Power Failure Mode	Yes
MCA		A	23			
MOCP		A	35			
Suggested Breaker Size		A	25			
Main Power Wire Size		AWG	Per Local Code			
Interconnecting Wire Size		AWG	14 / 4			

DIMENSIONS

INDOOR UNIT

Unit: inch

FLR36HP230V1R32AH

DIMENSIONS

A	61 13/16
B	9 1/4
C	59 17/32
D	11 1/32
E	26 3/16

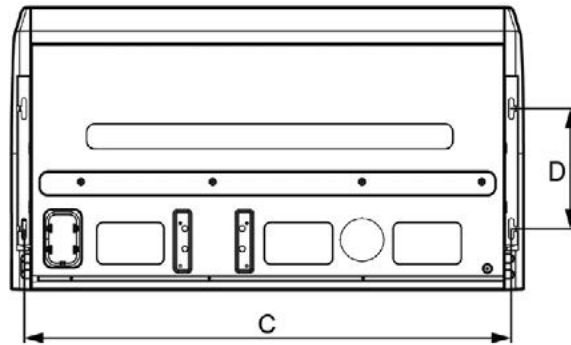
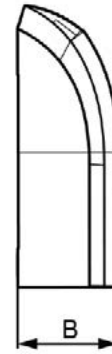
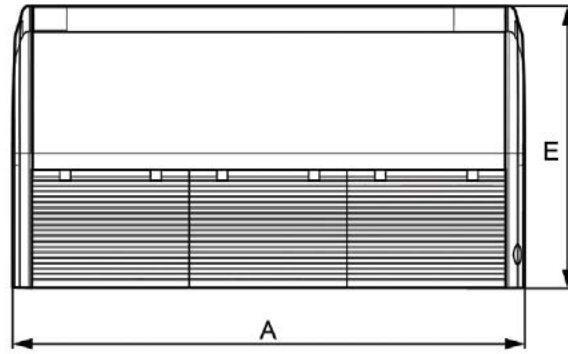

OUTDOOR UNIT

Unit: inch

LIV36HP230V1R32AO

DIMENSIONS

A	36 11/32
B	39 3/8
C	29 3/8
D	14 17/32
E	16 13/16
F	24 1/64
G	15 35/64

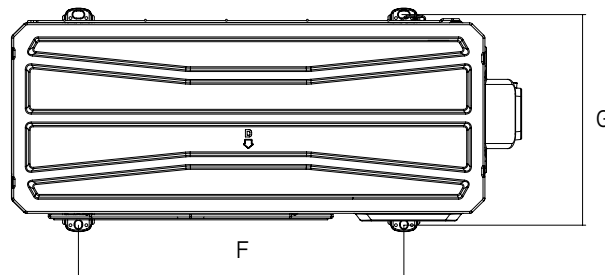
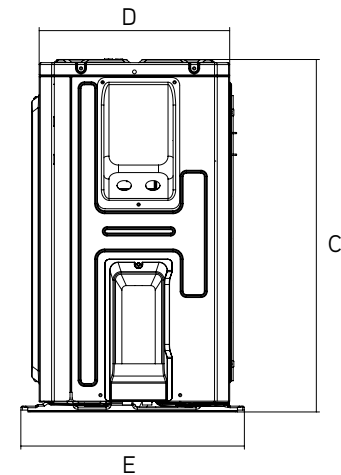
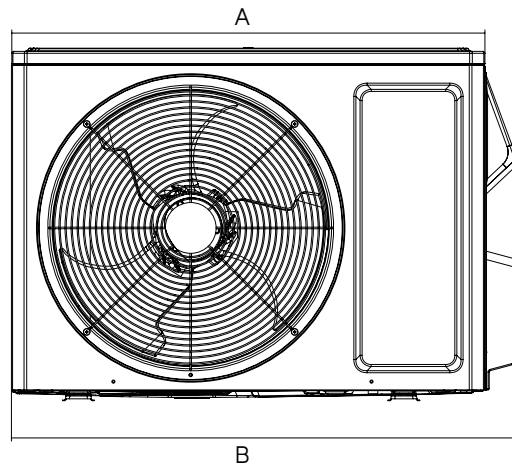

CLEARANCES

INDOOR UNIT

Minimum clearance

DIMENSIONS	
A	60
B	12
C	39
D	6
E	90

Unit: inch

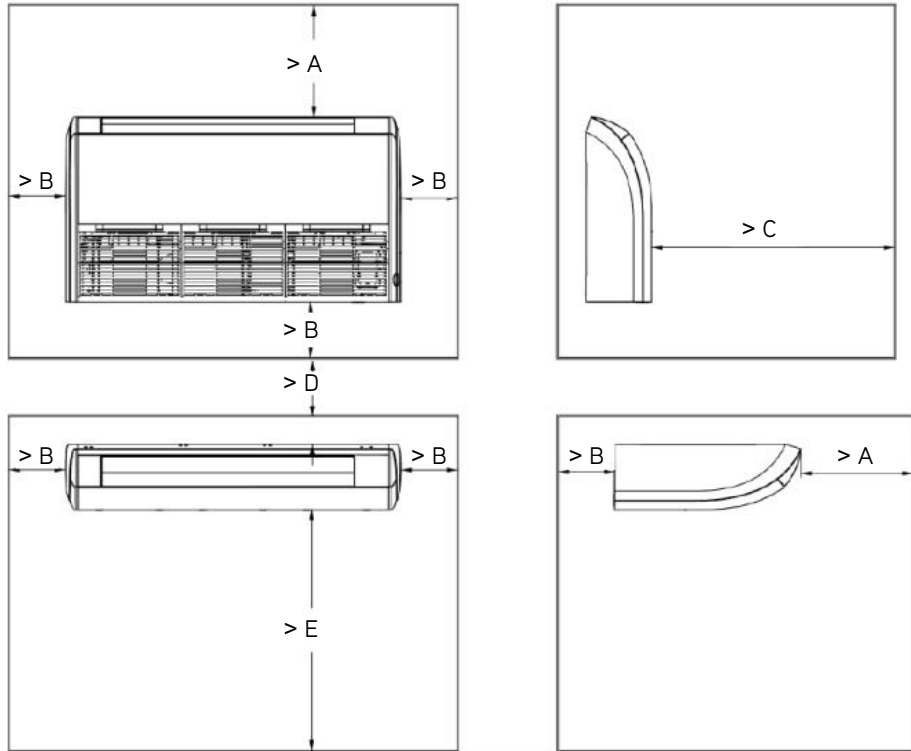

OUTDOOR UNIT

Minimum clearance

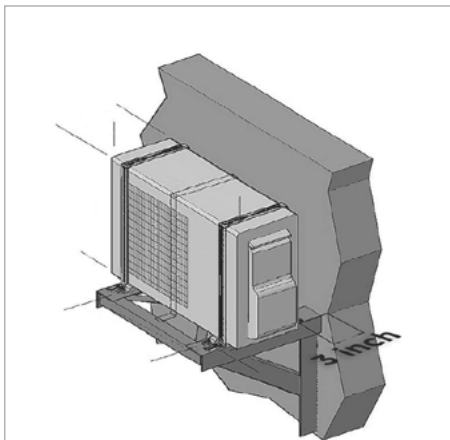

NOTE:
If bottom of the unit is free of airflow obstructions similar to the mounting bracket figure, the clearance to the wall on the back can be reduced to 3 inches.

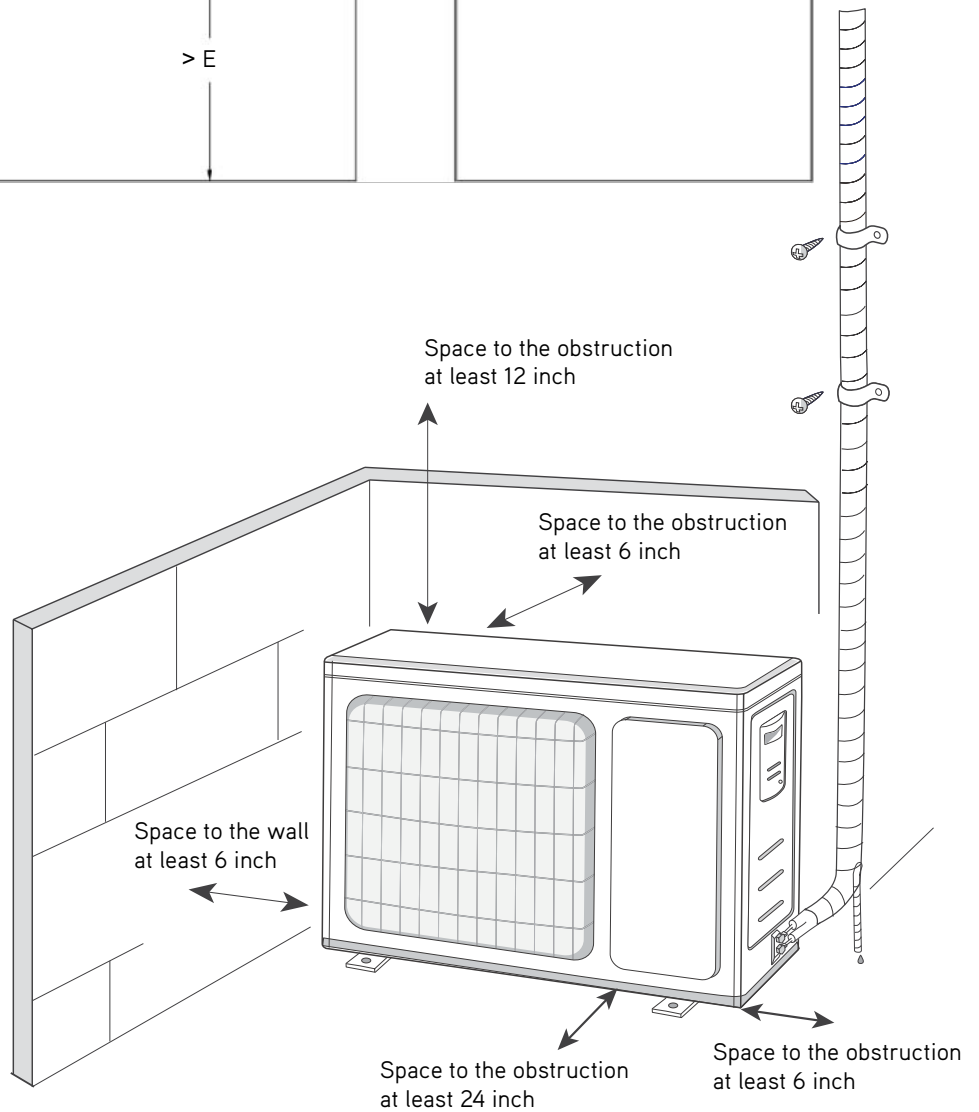

Specifications are subject to change without notice. Manufacturer reserves the right to discontinue or modify specifications or designs without notice or without incurring obligations. All Rights reserved.