



SUBMITTAL DATA

FSU36HP230V1R32AH
36000 BTU/H Floor Standing Unit Heat Pump System

Job Name	Location	Date
Purchaser	Engineer	
Submitted to	For	
Unit Designation	Schedule No.	

	
YBE1FB8F	FSU36HP230V1R32AH

GENERAL FEATURES

- AHRI Certificate: [215415558](#)
- Quiet Operation and Multiple Fan Speed
- Swing Louver Control
- Multi-Directional Air Flow
- Wireless Remote with LCD Display Included
- Remote and Panel Control Option
- Low Ambient Cooling and Heating
- (Indoor and Outdoor) Copper Tube / Aluminum Fin
- Blue Colored Fin - 500 Hrs Salt Spray Tested
- New R32 Refrigerant with Refrigerant Sensor

SPECIFICATIONS, FEATURES & FUNCTION SUMMARY

INDOOR MODEL		FSU36HP230V1R32AH		FEATURES & FUNCTIONS SUMMARY	
System Type		HEAT PUMP			
Outdoor Model		LIV36HP230V1R32AO			
SYSTEM PERFORMANCE				SYSTEM FEATURES	
Cooling	Min - Max	Btu/h	25,837 - 45,216	Inverter Type	G20 with Field Oriented control (FOC)
	Capacity @95°F	Btu/h	33,600	Ultra Low Frequency Torque Control	Yes
Heating	Min - Max	Btu/h	18,175 - 37,092	Power Factor Correction	Yes
	Capacity @47°F	Btu/h	34,000	Compressor Type - Inverter	High Efficiency Rotary
	Capacity @17°F	Btu/h	24,400	Basepan With Electric Heater	Yes
	Capacity Max @5°F	Btu/h	24,400	Indoor & Outdoor Fin Coating (Blue Fin)	Yes
SEER2			Intelligent Defrosting	Yes	
EER2			Intelligent Preheating	Yes	
HSPF2			Low Voltage Startup	Yes	
COP @5°F			Memory/Power Failure Recovery	Yes	
COP @47°F			Self Diagnosis	Yes	
Cooling Temperature Range	°F		Wired Controller Interface	Yes	
Heating Temperature Range	°F		WiFi Included	No	
Refrigerant Type			Indoor Fan Type	Centrifugal	
INDOOR UNIT		FSU36HP230V1R32AH		Multi Fan Speeds	4 Speeds
Air flow (Min-Max)	CFM	883 - 1148		Indoor Unit Display	Yes
Sound Pressure Level (Min - Max)	dB(A)	48 - 54		Auxiliary Electrical Heater	No
Dehumidification	pt/hr	7.40		Ventilation (Outdoor Air)	No
External Dimensions (L x D x H)	in	23-7/64 x 15-33/64 x 74-6/64		REMOTE CONTROLLER FUNCTIONS	
Package Dimension (L x W x H)	in	28-10/64 x 18-32/64 x 83-42/64		Auto Mode	Yes
Net Weight	lbs	130.1		Auto Clean	Yes
Gross Weight	lbs	156.6		Auto Fan	Yes
OUTDOOR UNIT		LIV36HP230V1R32AO		Auto Swing (Horizontal Auto Swing)	Yes
Sound Pressure Level	dB(A)	62		Auto Swing - 180° (Vertical Auto Swing)	Yes
External Dimensions (L x D x H)	in	39-3/8 x 15-13/16 x 29-3/8		Clock	Yes
Package Dimension (L x W x H)	in	42-33/64 x 19-1/64 x 31-57/64		Dry Mode	Yes
Net Weight	lbs	122.4		Dry Anti-Mildew (X-Fan) Mode	Yes
Gross Weight	lbs	133.4		Energy Saving Mode	Yes
REFRIGERANT PIPING				Dirty Filter Alert	No
Refrigerant Charge - R410A	oz	56.4		Fan Speed Control (7 Speeds)	Yes
Additional Charge	oz/ft	0.4		I Feel Function	No
Line Set Sized by Indoor Unit (Liquid - Gas)	in	1/4 - 5/8		Privacy Lock	Yes
Line Set Size (Liquid - Gas) - Flared Connections	in	1/4 - 5/8		Quiet Mode	No
Pre-Charge Length	ft	25		Intelligent Preheating	Yes
Pipe Length (Min - Max)	ft	10 - 131		Sleep Mode	Yes
Max. Pipe Elevation	ft	82		3 Sleep Mode Options	Yes
ELECTRICAL				Timer Mode	Yes
Power Supply	208-230V / 1Ph / 60Hz (Powered by the Outdoor Unit)			Turbo Mode	Yes
Voltage Range (Min - Max)	VAC	187 - 253		Display On/Off Control	Yes
Rated Current - Cooling	A	20		Intelligent Defrosting	Yes
Rated Current - Heating	A	20		Power Failure Mode	Yes
MCA	A	23			
MOCP	A	35			
Suggested Breaker Size	A	25			
Main Power Wire Size	AWG	Per Local Code			
Interconnecting Wire Size	AWG	14 / 4			

DIMENSIONS

INDOOR UNIT

Unit: inch

FSU36HP230V1R32AH

DIMENSIONS

W	23 7/64
H	74 3/32
D	15 33/64

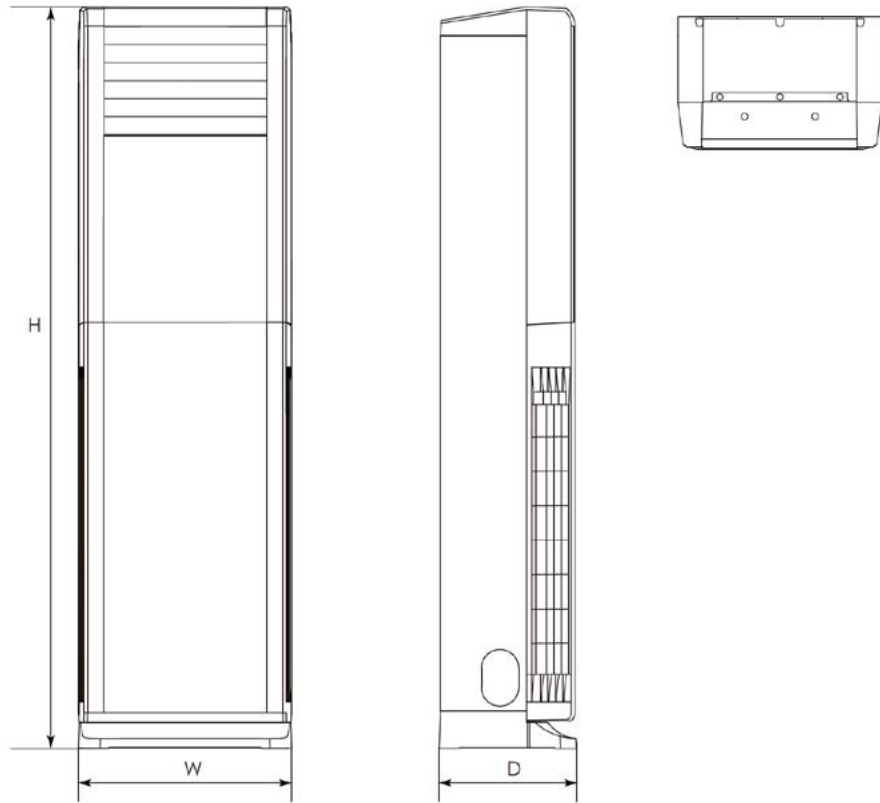

OUTDOOR UNIT

Unit: inch

LIV36HP230V1R32AO

DIMENSIONS

A	36 11/32
B	39 3/8
C	29 3/8
D	14 17/32
E	16 13/16
F	24 1/64
G	15 35/64

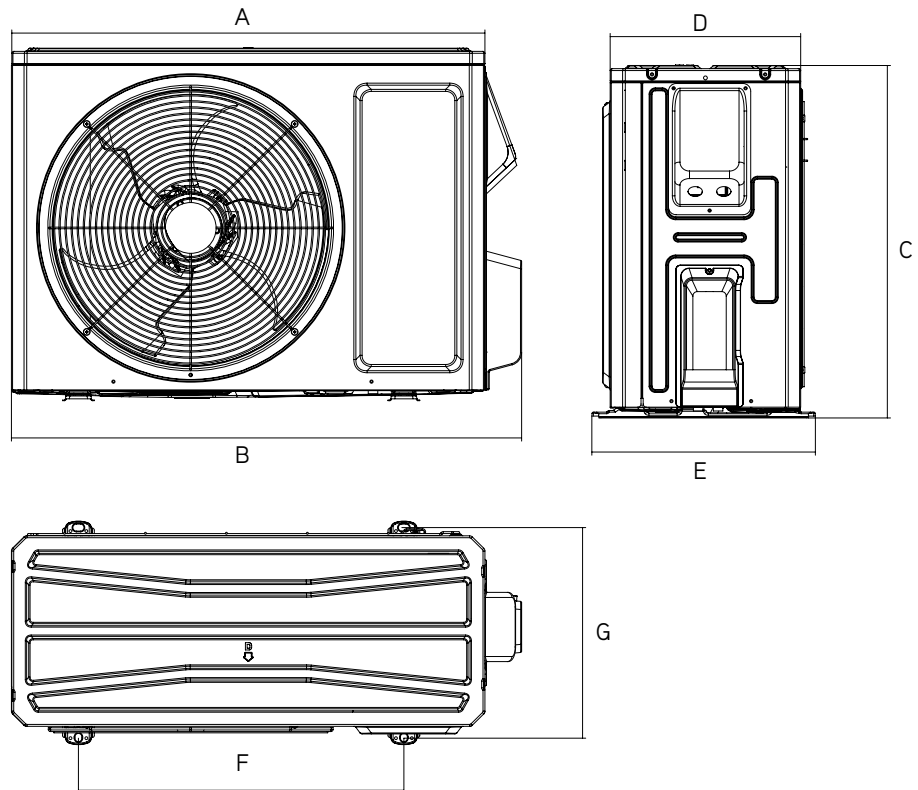

CLEARANCES

INDOOR UNIT

Minimum clearance

DIMENSIONS	
A	60
B	12
C	39
D	6
E	90

Unit: inch

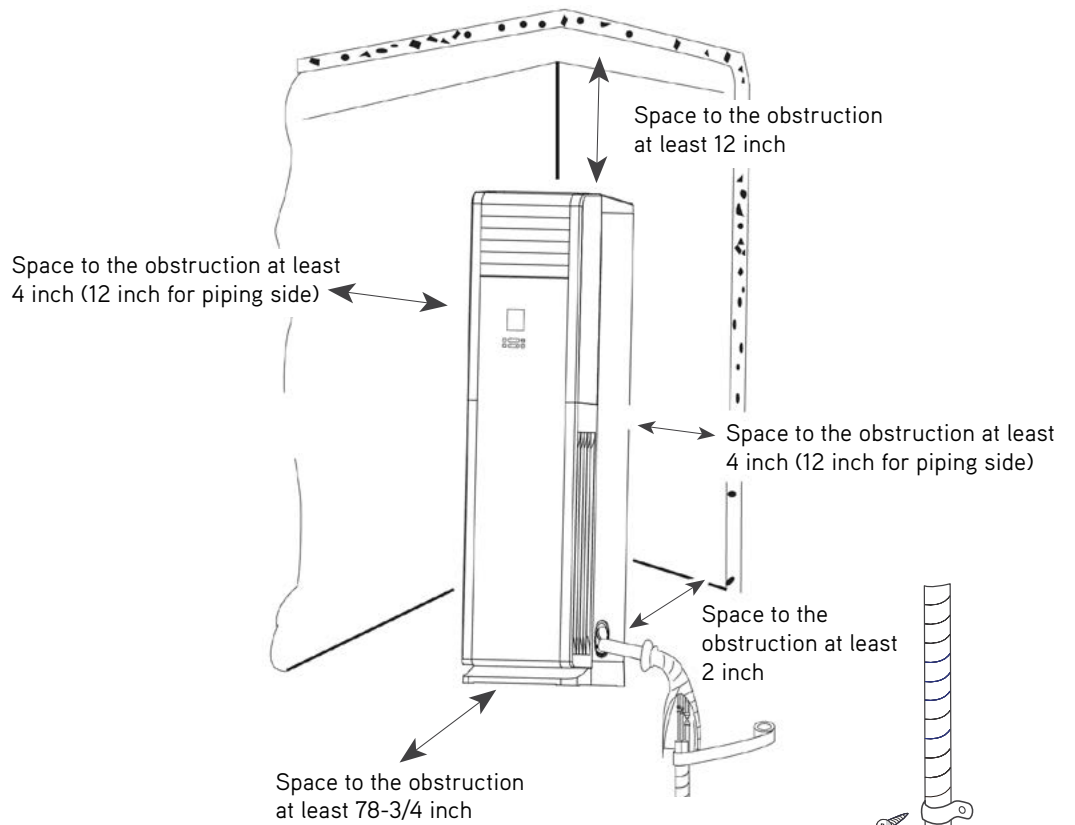

OUTDOOR UNIT

Minimum clearance

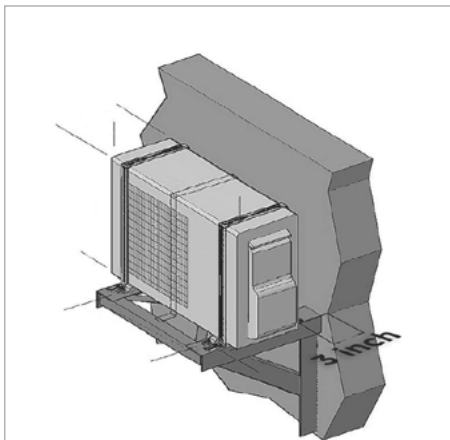

NOTE:

If bottom of the unit is free of airflow obstructions similar to the mounting bracket figure, the clearance to the wall on the back can be reduced to 3 inches.

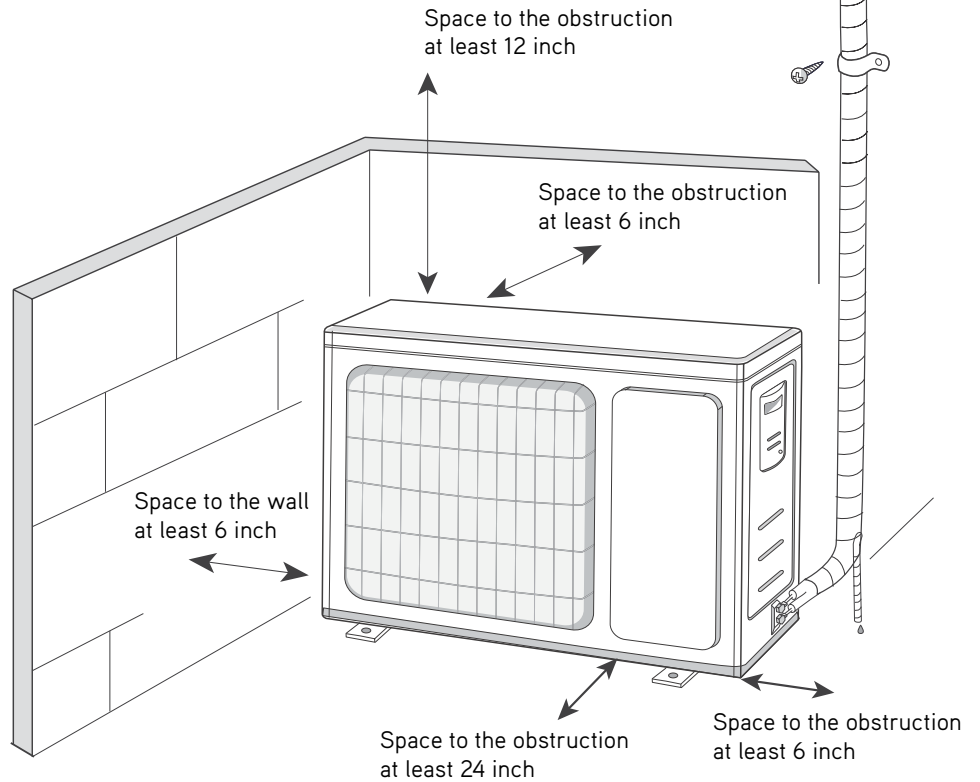

Specifications are subject to change without notice. Manufacturer reserves the right to discontinue or modify specifications or designs without notice or without incurring obligations. All Rights reserved.