



SUBMITTAL DATA

CON18HP230V1R32AH
18000 BTU/H Mini Console Heat Pump System

Job Name	Location	Date
Purchaser	Engineer	
Submitted to	For	
Unit Designation	Schedule No.	

		
YBE1FB5F	CON18HP230V1R32AH	XE72-44/E (Optional)

GENERAL FEATURES

- AHRI Certificate: 215417461 (Vireo R32), 215417454 (Envo R32)
- Quiet Operation and Multi-Speed Fan
- 2-Way Discharge Air
- Swing Louver Control
- Multi-Directional Air Flow
- Wireless Remote with LCD Display
- Optional XE72-44/E Wired Controller
- Low Ambient Cooling and Heating
- (Indoor and Outdoor) Copper Tube / Aluminum Fin
- Blue Colored Fin - 500 Hrs Salt Spray Tested
- New R32 Refrigerant with Refrigerant Sensor

SPECIFICATIONS, FEATURES & FUNCTION SUMMARY

INDOOR MODEL		CON18HP230V1R32AH	
System Type		HEAT PUMP	
Outdoor Model		VIR18HP230V1R32AO	ENV18HP230V1R32AO
SYSTEM PERFORMANCE			
Cooling	Min - Max	Btu/h	5,100 - 23,200
	Capacity @95°F	Btu/h	18,000
Heating	Min - Max	Btu/h	9,987 - 21,599
	Capacity @47°F	Btu/h	18,000
	Capacity @17°F	Btu/h	10,800
	Capacity Max @5°F	Btu/h	12,900
SEER2			21.5
EER2			11.6
HSPF2			8.5
COP @5°F			1.80
Cooling Temperature Range		°F	-20 - 122
Heating Temperature Range		°F	-22 - 86
Refrigerant Type			R32
INDOOR UNIT		CON18HP230V1R32AH	
Air flow (Min-Max)		CFM	241 - 494
Sound Pressure Level (Min - Max)		dB(A)	32 - 47
Dehumidification		pt/hr	3.8
External Dimensions (L x D x H)		in	27-9/16 x 8-15/32 x 23-5/8
Package Dimension (L x W x H)		in	31-1/32 x 11-9/64 x 27-7/16
Net Weight		lbs	33.1
Gross Weight		lbs	39.7
OUTDOOR UNIT		VIR18HP230V1R32AO	ENV18HP230V1R32AO
Sound Pressure Level		dB(A)	59
External Dimensions (L x D x H)		in	37-23/32 x 15-53/64 x 25-63/64
Package Dimension (L x W x H)		in	40-5/8 x 17-61/64 x 29-1/64
Net Weight		lbs	94.8
Gross Weight		lbs	104.7
REFRIGERANT PIPING			
Refrigerant Charge - R410A		oz	40.6
Additional Charge		oz/ft	0.2
Line Set Sized by Indoor Unit (Liquid - Gas)		in	1/4 - 1/2
Line Set Size (Liquid - Gas) - Flared Connections		in	1/4 - 1/2
Pre-Charge Length		ft	25
Pipe Length (Min - Max)		ft	10 - 131
Max. Pipe Elevation		ft	82
ELECTRICAL			
Power Supply		208-230V / 1Ph / 60Hz (Powered by the Outdoor Unit)	
Voltage Range (Min - Max)		VAC	187 - 253
Rated Current - Cooling		A	5.9
Rated Current - Heating		A	7.8
MCA		A	11
MOCP		A	15
Suggested Breaker Size		A	20
Main Power Wire Size		AWG	Per Local Code
Interconnecting Wire Size		AWG	14 / 4

FEATURES & FUNCTIONS SUMMARY

SYSTEM FEATURES

Inverter Type	G20 with Field Oriented control (FOC)
Ultra Low Frequency Torque Control	Yes
Power Factor Correction	Yes
Compressor Type - Inverter	High Efficiency Rotary
Basepan With Electric Heater	Yes
Indoor & Outdoor Fin Coating (Blue Fin)	Yes
Intelligent Defrosting	Yes
Intelligent Preheating	Yes
Low Voltage Startup	Yes
Memory/Power Failure Recovery	Yes
Self Diagnosis	Yes
Wired Controller Interface	Yes
WiFi Included	No
Indoor Fan Type	Centrifugal
Multi Fan Speeds	7 Speeds
Indoor Unit Display	No
Auxiliary Electrical Heater	No
Ventilation (Outdoor Air)	No

REMOTE CONTROLLER FUNCTIONS

Auto Mode	Yes
Auto Fan	Yes
Auto Swing (Horizontal Auto Swing)	No
Auto Swing - 180° (Vertical Auto Swing)	Yes
Clock	Yes
Dry Mode	Yes
Dry Anti-Mildew (X-Fan) Mode	Yes
Energy Saving Mode	Yes
Dirty Filter Alert	No
Fan Speed Control (7 Speeds)	Yes
I Feel Function	Yes
Privacy Lock	Yes
Quiet Mode	Yes
Room Temperature Display	No
Sleep Mode	Yes
3 Sleep Mode Options	Yes
Timer Mode	Yes
Turbo Mode	Yes
Display On/Off Control	Yes
Freeze Guard Mode	Yes
Power Failure Mode	Yes

NOTE:

Please check the Multi-zone submittals for Non-Ducted or Mixed Performance table.

DIMENSIONS

INDOOR UNIT

Unit: inch

CON18HP230V1R32AH

DIMENSIONS

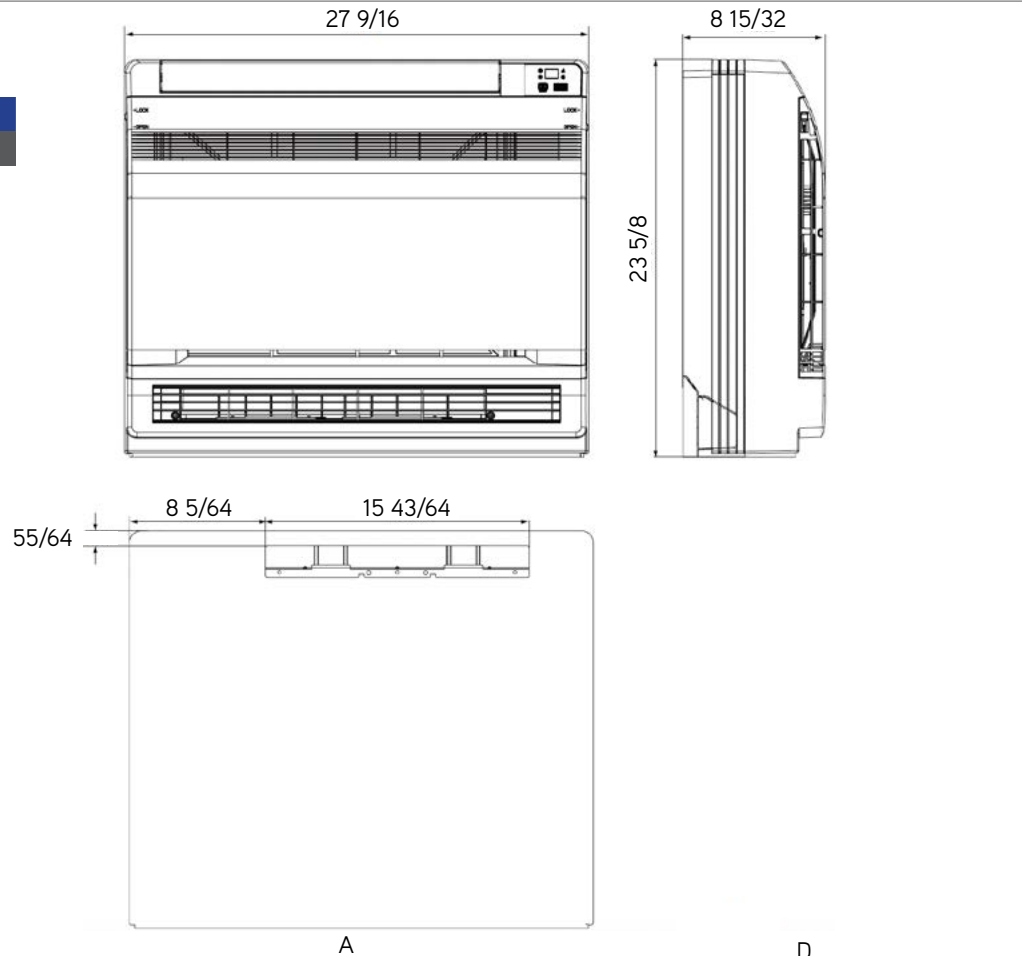

OUTDOOR UNIT

Unit: inch

VIR18HP230V1R32AO

DIMENSIONS

A	35
B	$37 \frac{23}{32}$
C	$25 \frac{63}{64}$
D	$13 \frac{25}{64}$
E	$15 \frac{53}{64}$
F	$22 \frac{7}{16}$
G	$14 \frac{39}{64}$

ENV18HP230V1R32AO

DIMENSIONS

A	35
B	$37 \frac{23}{32}$
C	$25 \frac{63}{64}$
D	$13 \frac{25}{64}$
E	$15 \frac{53}{64}$
F	$22 \frac{7}{16}$
G	$14 \frac{39}{64}$

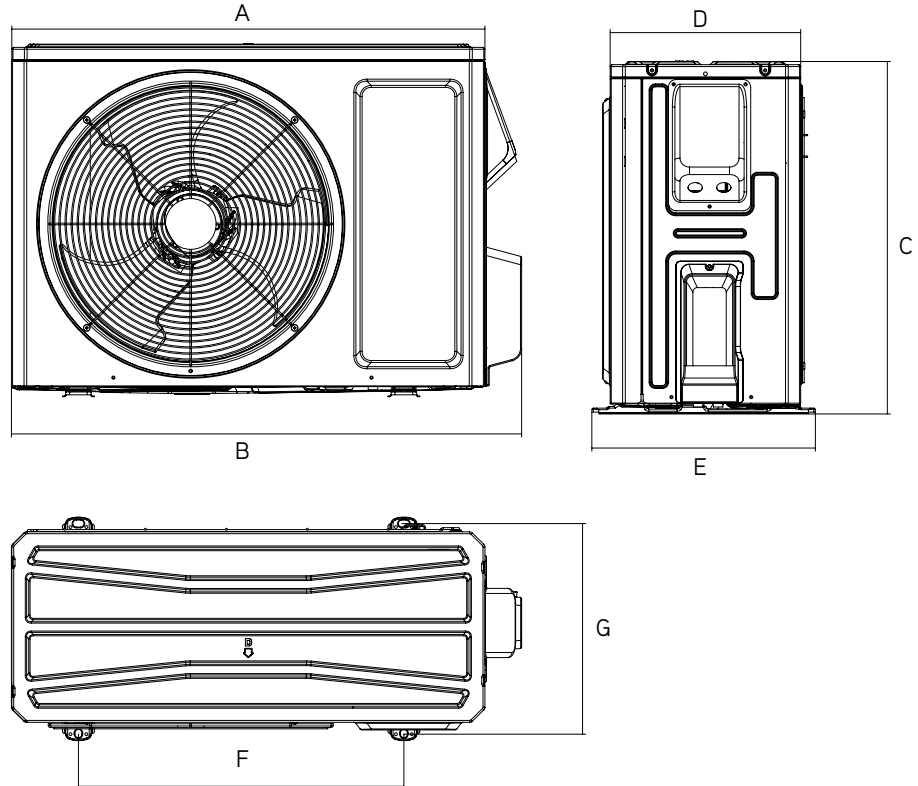

CLEARANCES

INDOOR UNIT

Minimum clearance

DIMENSIONS	
A	2-3/4
B	2
C	39

Unit: inch

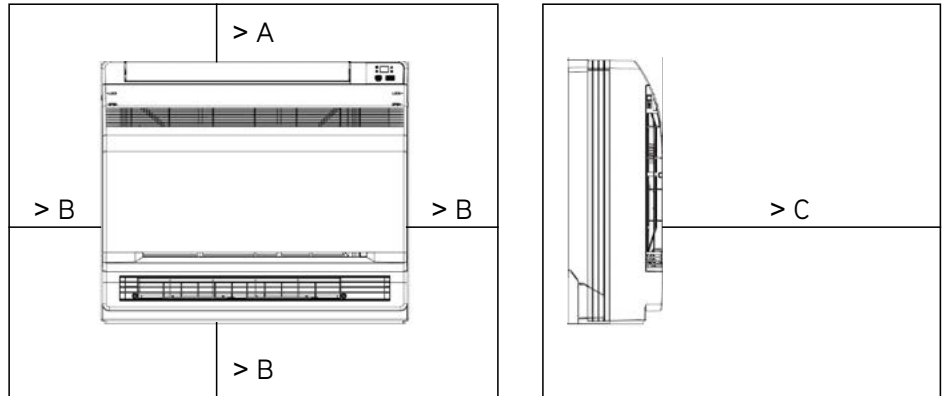

OUTDOOR UNIT

Minimum clearance

NOTE:
If bottom of the unit is free of airflow obstructions similar to the mounting bracket figure, the clearance to the wall on the back can be reduced to 3 inches.

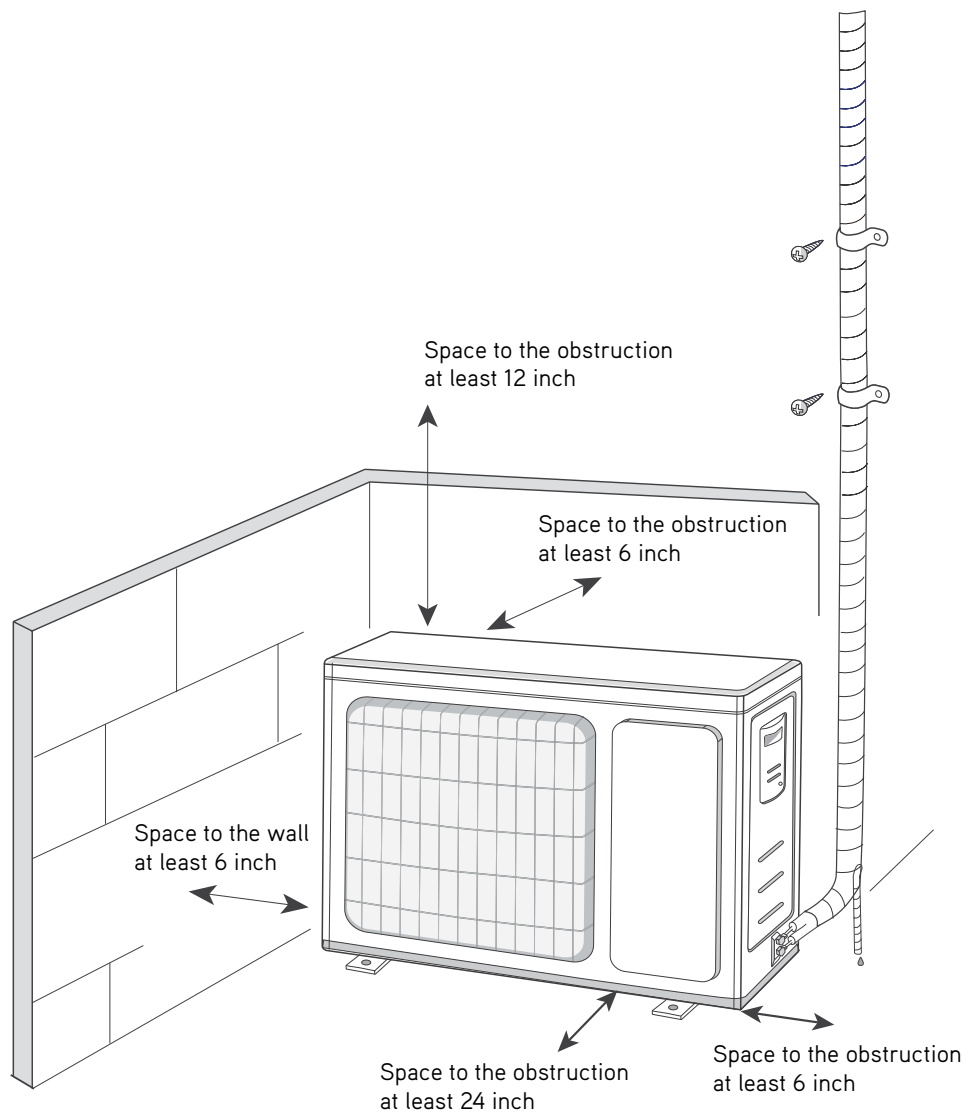

Specifications are subject to change without notice. Manufacturer reserves the right to discontinue or modify specifications or designs without notice or without incurring obligations. All Rights reserved.