

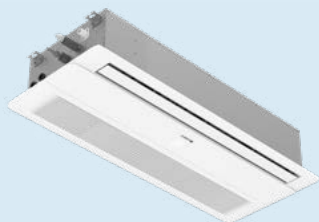

SUBMITTAL DATA

OWC18HP230V1R32AH
18000 BTU/H One Way Cassette Heat Pump System

Job Name	Location	Date
Purchaser	Engineer	
Submitted to	For	
Unit Designation	Schedule No.	
		
YBE1FB5F	OWC18HP230V1R32AH	XE72-44/E

GENERAL FEATURES

- AHRI Certificate: 215417456 (Vireo R32), 215417449 (Envo R32), 215416022 (Sapphire R32)
- High Efficiency DC Inverter Technology
- Compact and Quiet Design
- Multiple Fan Speeds
- Swing Louver Control
- Internal Condensate Drain Pump W/ Sentry Float Switch
- Wireless Remote with LCD Display Included
- XE72-44/E Wired Controller Included
- Low Ambient Cooling and Heating
- (Indoor and Outdoor) Copper Tube / Aluminum Fin
- Blue Colored Fin - 500 Hrs Salt Spray Tested
- New R32 Refrigerant with Refrigerant Sensor

SPECIFICATIONS, FEATURES & FUNCTION SUMMARY

INDOOR MODEL		OWC18HP230V1R32AH			
System Type		HEAT PUMP			
Outdoor Model		VIR18HP230V1R32AO	ENV18HP230V1R32AO	SAP18HP230V1R32AO	
SYSTEM PERFORMANCE					
Cooling	Min - Max	Btu/h	5,100 - 23,200	5,100 - 23,200	5,100 - 23,200
	Capacity @95°F	Btu/h	18,000	18,000	18,000
	Min - Max	Btu/h	5,800 - 23,500	5,800 - 23,500	5,800 - 23,500
Heating	Capacity @47°F	Btu/h	18,000	18,000	18,000
	Capacity @17°F	Btu/h	10,100	10,100	11,000
	Capacity Max @5°F	Btu/h	12,600	12,600	13,500
SEER2			21.5	21.5	23.5
EER2			10.9	10.9	10.90
HSPF2			8.5	8.5	8.7
COP @5°F			1.80	1.80	1.80
Cooling Temperature Range		°F	-20 - 122		
Heating Temperature Range		°F	-22 - 86		
Refrigerant Type		R32			
INDOOR UNIT		OWC18HP230V1R32AH			
Air flow (Min-Max)		CFM	265 - 412		
Sound Pressure Level (Min - Max)		dB(A)	35 - 43		
Dehumidification		pt/hr	3.8		
External Dimensions (L x D x H)		in	38-55/64 x 15-5/32 x 7-1/64		
Package Dimension (L x W x H)		in	51-29/64 x 19-23/32 x 12-13/64		
Net Weight		lbs	44.1		
Gross Weight		lbs	59.5		
CASSETTE GRILLE (REQUIRED)		GREETD01			
Grille Dimension (L x D x H)		in	47-1/4 x 18-7/64 x 2-11/64		
Package Dimension (L x W x H)		in	49-13/16 x 21-1/8 x 4-25/32		
Weight (Net / Gross)		lbs	9.26 / 13.23		
OUTDOOR UNIT		VIR18HP230V1R32AO	ENV18HP230V1R32AO	SAP18HP230V1R32AO	
Sound Pressure Level		dB(A)	59	59	59
External Dimensions (L x D x H)		in	37-23/32 x 15-53/64 x 25-63/64	37-23/32 x 15-53/64 x 25-63/64	37-23/32 x 15-53/64 x 25-63/64
Package Dimension (L x W x H)		in	40-5/8 x 17-61/64 x 29-1/64	40-5/8 x 17-61/64 x 29-1/64	40-5/8 x 17-61/64 x 29-1/64
Net Weight		lbs	94.8	94.8	94.8
Gross Weight		lbs	104.7	104.7	104.7
REFRIGERANT PIPING					
Refrigerant Charge - R410A		oz	40.6	40.6	47.6
Additional Charge		oz/ft	0.2	0.2	0.4
Line Set Sized by Indoor Unit (Liquid - Gas)		in	1/4 - 1/2		
Line Set Size (Liquid - Gas) - Flared Connections		in	1/4 - 1/2	1/4 - 1/2	1/4 - 5/8
Pre-Charge Length		ft	25		
Pipe Length (Min - Max)		ft	10 - 131	10 - 131	10 - 131
Max. Pipe Elevation		ft	82	82	82
ELECTRICAL					
Power Supply		208-230V / 1Ph / 60Hz (Powered by the Outdoor Unit)			
Voltage Range (Min - Max)		VAC	187 - 253		
Rated Current - Cooling		A	11.5	5.9	12.5
Rated Current - Heating		A	11.5	7.8	16
MCA		A	16	11	20
MOCP		A	20	15	25
Suggested Breaker Size		A	20	15	20
Main Power Wire Size		AWG	Per Local Code		
Interconnecting Wire Size		AWG	14 / 4		

FEATURES & FUNCTIONS SUMMARY

SYSTEM FEATURES

Inverter Type	G20 with Field Oriented control (FOC)
Ultra Low Frequency Torque Control	Yes
Power Factor Correction	Yes
Compressor Type - Inverter	High Efficiency Rotary
Basepan With Electric Heater	Yes
Indoor & Outdoor Fin Coating (Blue Fin)	Yes
Intelligent Defrosting	Yes
Intelligent Preheating	Yes
Low Voltage Startup	Yes
Memory/Power Failure Recovery	Yes
Self Diagnosis	Yes
Wired Controller Interface	Yes
WiFi Included	No
Indoor Fan Type	Centrifugal
Multi Fan Speeds	4 Speeds
Indoor Unit Display	Yes
Auxiliary Electrical Heater	No
Ventilation (Outdoor Air)	Yes

REMOTE CONTROLLER FUNCTIONS

Auto Mode	Yes
Auto Fan	Yes
Auto Swing (Horizontal Auto Swing)	No
Auto Swing - 180° (Vertical Auto Swing)	Yes
Clock	Yes
Dry Mode	Yes
Dry Anti-Mildew (X-Fan) Mode	Yes
Energy Saving Mode	Yes
Dirty Filter Alert	No
Fan Speed Control (7 Speeds)	Yes
I Feel Function	Yes
Privacy Lock	Yes
Quiet Mode	Yes
Room Temperature Display	No
Sleep Mode	Yes
3 Sleep Mode Options	Yes
Timer Mode	Yes
Turbo Mode	Yes
Display On/Off Control	Yes
Freeze Guard Mode	Yes
Power Failure Mode	Yes

NOTE:

Please check the Multi-zone submittals for Non-Ducted or Mixed Performance table.

DIMENSIONS

INDOOR UNIT

Unit: inch

OWC18HP230V1R32AH	
DIMENSIONS	
A	47-1/4
B	43-57/64
C	40-7/16
D	38-55/64
E	18-7/64
F	16-11/32
G	15-5/32
H	10-9/32

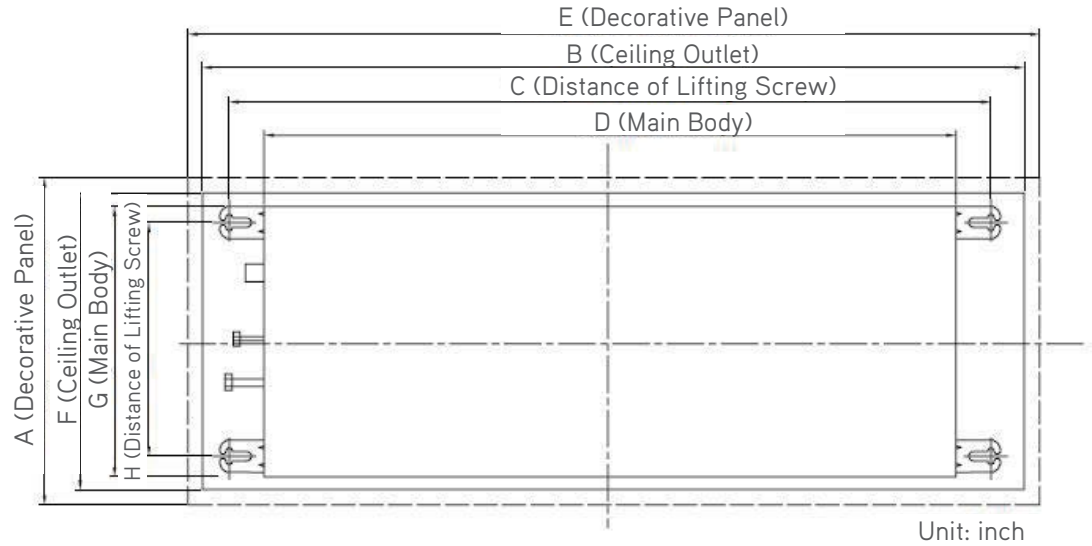

OUTDOOR UNIT

Unit: inch

VIR18HP230V1R32AO	
DIMENSIONS	
A	35
B	37 23/32
C	25 63/64
D	13 25/64
E	15 53/64
F	22 7/16
G	14 39/64

ENV18HP230V1R32AO	
DIMENSIONS	
A	35
B	37 23/32
C	25 63/64
D	13 25/64
E	15 53/64
F	22 7/16
G	14 39/64

SAP18HP230V1R32AO	
DIMENSIONS	
A	35
B	37 23/32
C	25 63/64
D	13 25/64
E	15 53/64
F	22 7/16
G	14 39/64

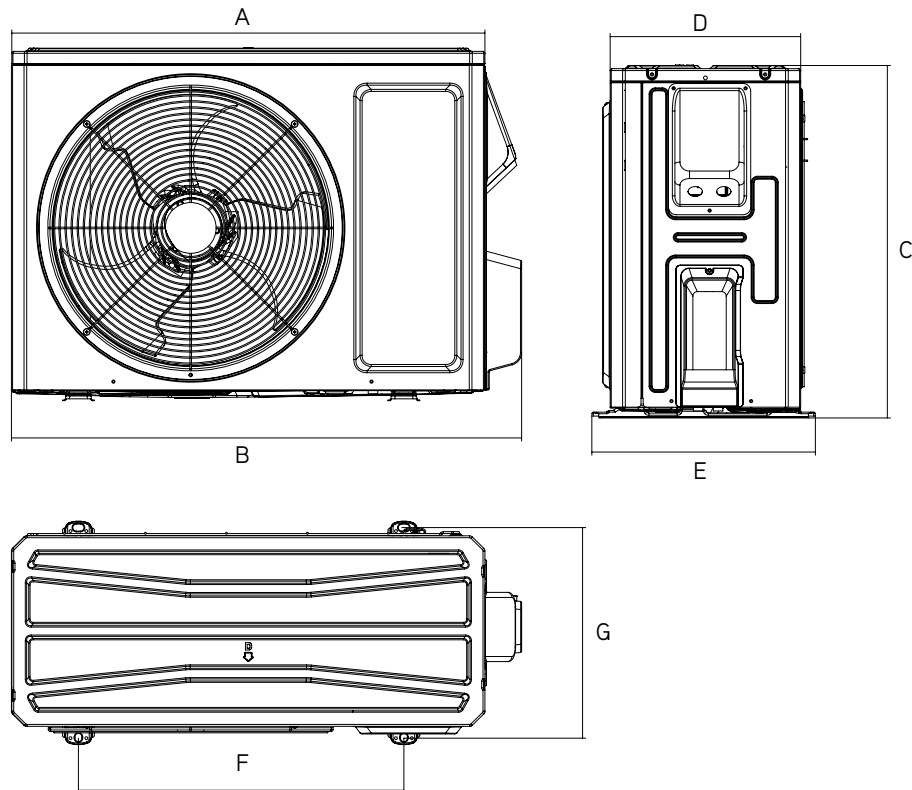

CLEARANCES

INDOOR UNIT

Minimum clearance

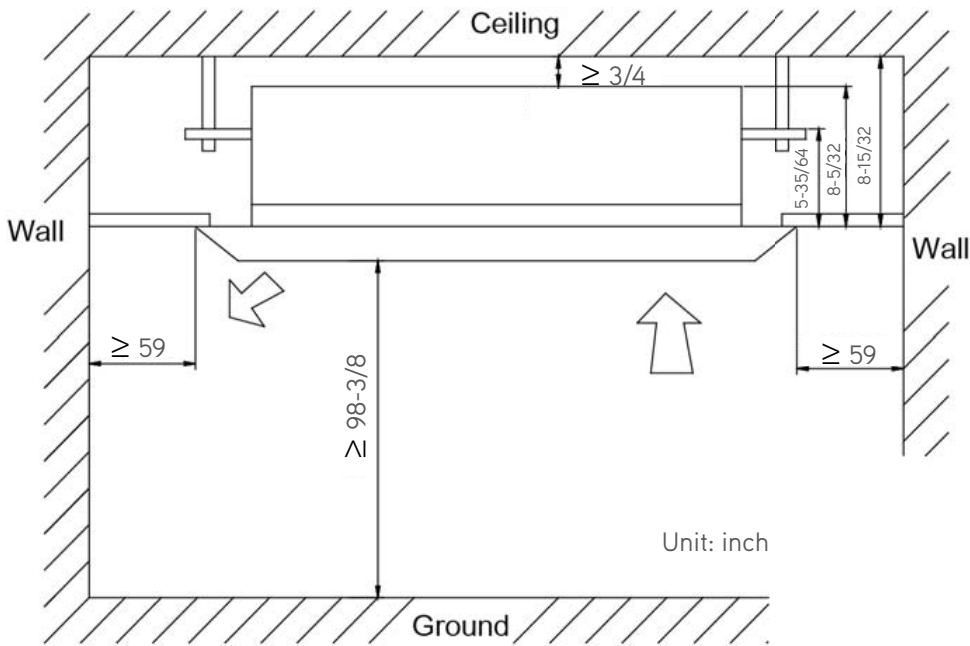

OUTDOOR UNIT

Minimum clearance

NOTE:
If bottom of the unit is free of airflow obstructions similar to the mounting bracket figure, the clearance to the wall on the back can be reduced to 3 inches.

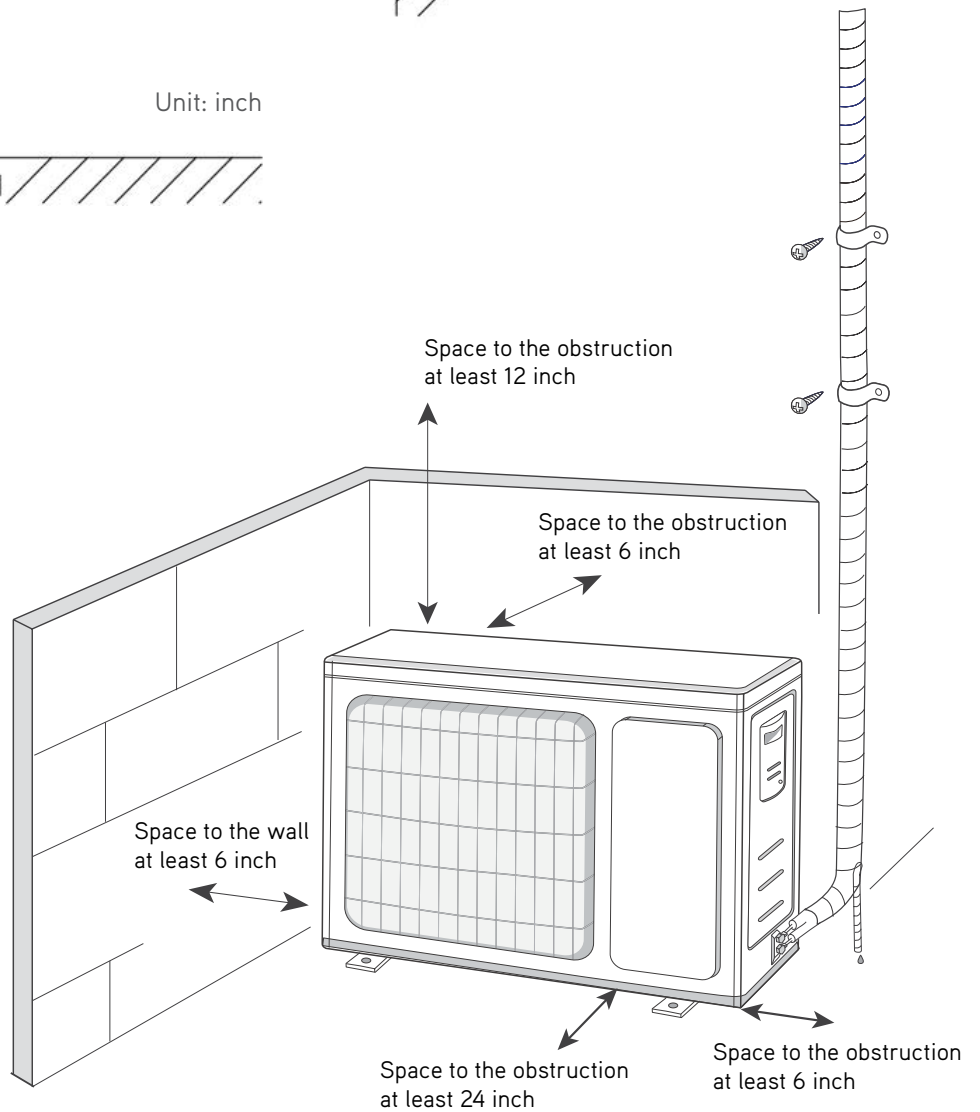

Specifications are subject to change without notice. Manufacturer reserves the right to discontinue or modify specifications or designs without notice or without incurring obligations. All Rights reserved.