

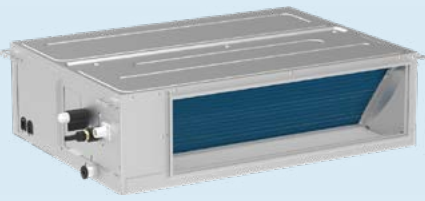

## SUBMITTAL DATA

DUC30HP230V1R32AH  
30000 BTU/H Slim Duct (HS) Heat Pump System

Job Name	Location	Date
Purchaser	Engineer	
Submitted to	For	
Unit Designation	Schedule No.	

		
YBE1FB5F	DUC30HP230V1R32AH	XE72-44/E

### GENERAL FEATURES

- AHRI Certificate: [215413818 \(Livo R32 30Btu/h\)](#)
- High Efficiency DC Inverter Technology
- Compact and Quiet Design
- Slim Line Construction
- High Static E.S.P Capability -Adjustible
- Internal Condensate Drain Pump
- Flexible Return Air From Bottom Or Rear
- Wireless Remote with LCD Display Included
- XE72-44/E Wi-Fi Wired Controller Included
- Low Ambient Cooling and Heating
- Coil (Indoor and Outdoor) Copper Tube / Aluminum Fin
- Blue Colored Fin - 500 Hrs Salt Spray Tested
- New R32 Refrigerant with Refrigerant Sensor

## SPECIFICATIONS, FEATURES & FUNCTION SUMMARY

SYSTEM TYPE			HEAT PUMP		FEATURES & FUNCTIONS SUMMARY	
Indoor Model			DUC30HP230V1R32AH		Inverter Type	
Outdoor Model			LIV30HP230V1R32AO		G20	
SYSTEM PERFORMANCE						
Cooling Capacity	Min - Max	Btu/h	18,760 - 38,881		Ultra Low Frequency Torque Control	
	Capacity @95°F	Btu/h	30,000		Yes	
Heating Capacity	Min - Max	Btu/h	14,405 - 33,460		Power Factor Correction	
	Capacity @47°F	Btu/h	30,000		Yes	
	Capacity @17°F	Btu/h	24,000		Compressor Type - Inverter	
	Capacity Max @5°F	Btu/h	20,400		High Efficiency Rotary	
SEER2			18.50		Basepan With Electric Heater	
EER2			11.25		Yes	
HSPF2			8.5		Indoor & Outdoor Fin Coating (Blue Fin)	
COP @5°F			1.80		Yes	
Cooling Temperature Range		°F	0 - 118		Intelligent Defrosting	
Heating Temperature Range		°F	-13 - 75		Yes	
Refrigerant Type			R32		Intelligent Preheating	
INDOOR UNIT			DUC30HP230V1R32AH		Low Voltage Startup	
Air flow (Min-Max)			CFM		Yes	
External Static Pressure (Max)			In W.c.		Memory/Power Failure Recovery	
Sound Pressure Level (Min - Max)			dB(A)		Yes	
Dehumidification			pt/hr		Self Diagnosis	
External Dimensions (L x D x H)			in		Yes	
Package Dimension (L x W x H)			in		Wired Controller Interface	
Net Weight			lbs		Yes	
Gross Weight			lbs		WiFi Included	
OUTDOOR UNIT			LIV30HP230V1R32AO		Indoor Fan Type	
Sound Pressure Level			dB(A)		Centrifugal	
External Dimensions (L x D x H)			in		Multi Fan Speeds	
Package Dimension (L x W x H)			in		4 Speeds	
Net Weight			lbs		Indoor Unit Display	
Gross Weight			lbs		No	
REFRIGERANT PIPING					Auxiliary Electrical Heater	
Refrigerant Charge - R32			oz		No	
Additional Charge			oz/ft		Ventilation (Outdoor Air)	
Line Set Sized by Indoor Unit (Liquid - Gas)			in		No	
Line Set Size (Liquid - Gas) - Flared Connections			in		No	
Pre-Charge Length			ft		Yes	
Pipe Length (Min - Max)			ft		Yes	
Max. Pipe Elevation			ft		Yes	
ELECTRICAL					REMOTE CONTROLLER FUNCTIONS	
Power Supply			208-230V / 1Ph / 60Hz (Powered by the Outdoor Unit)		Auto Mode	
Voltage Range (Min - Max)		VAC	187 - 253		Yes	
Rated Current - Cooling		A	20		Auto Fan	
Rated Current - Heating		A	20		Yes	
MCA		A	25.6		Auto Swing (Horizontal Auto Swing)	
MOCP		A	35		No	
Suggested Breaker Size		A	30		Auto Swing - 180° (Vertical Auto Swing)	
Main Power Wire Size		AWG	Per Local Code		No	
Interconnecting Wire Size		AWG	14 / 4		Clock	
					Yes	
					Dry Mode	
					Yes	
					Dry Anti-Mildew (X-Fan) Mode	
					Yes	
					Energy Saving Mode	
					Yes	
					Dirty Filter Alert	
					No	
					Fan Speed Control (7 Speeds)	
					Yes	
					I Feel Function	
					Yes	
					Privacy Lock	
					Yes	
					Quiet Mode	
					No	
					Room Temperature Display	
					No	
					Sleep Mode	
					Yes	
					3 Sleep Mode Options	
					No	
					Timer Mode	
					Yes	
					Turbo Mode	
					Yes	
					Display On/Off Control	
					No	
					Freeze Guard Mode	
					Yes	
					Power Failure Mode	
					Yes	

## FAN PERFORMANCE

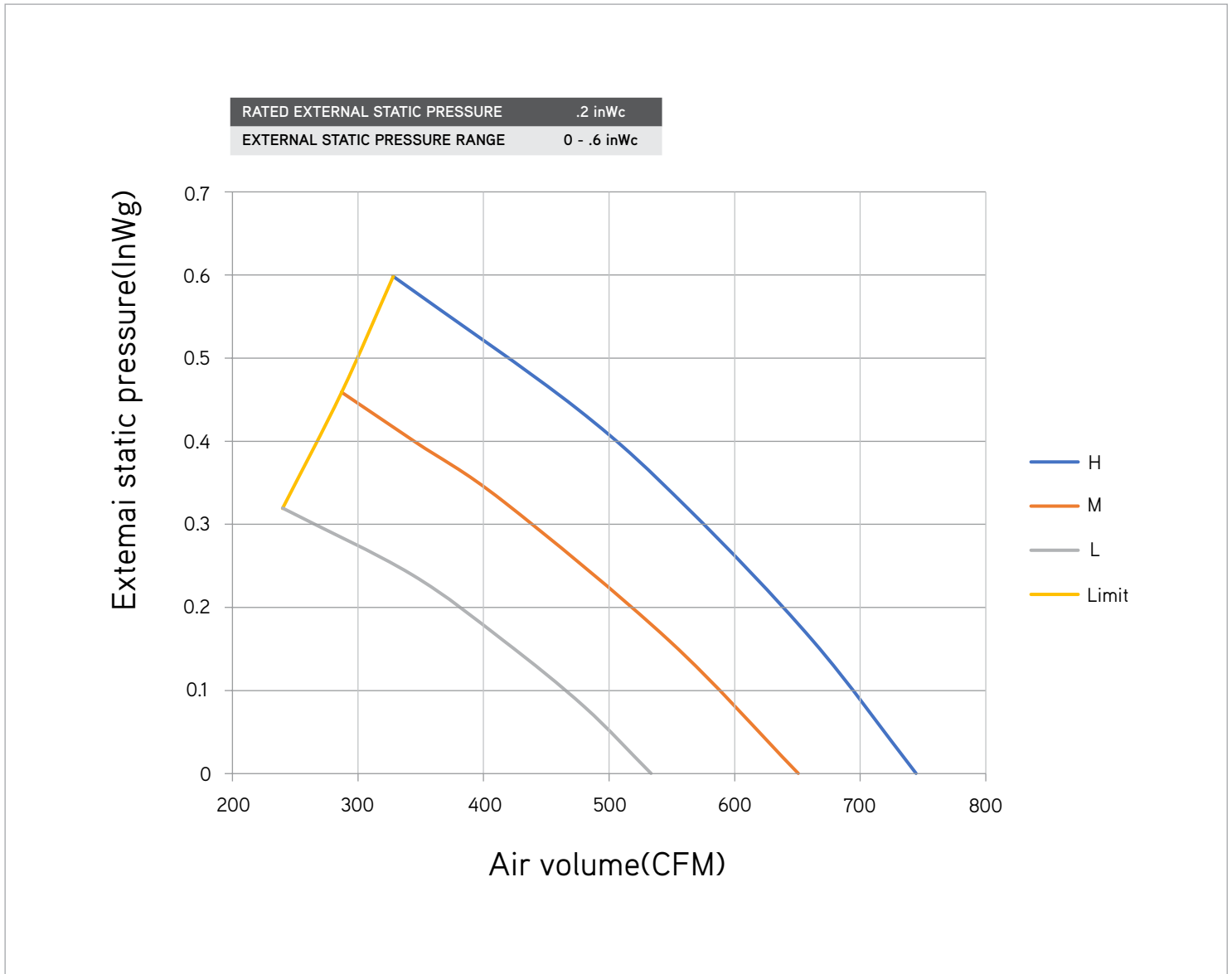

**NOTE:**

The static pressure is adjusted using the wired controller. Refer to the wired controller instruction manual for more information.

## DIMENSIONS

### INDOOR UNIT

Unit: inch

DUC30HP230V1R32AH	
DIMENSIONS	
A	37 3/32
B	23 15/64
C	35 7/16
D	10 15/64
E	25 25/32
F	27 1/4

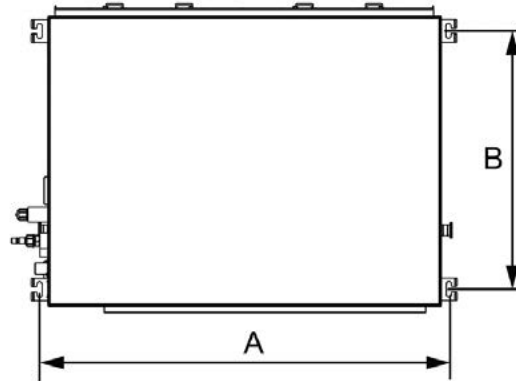
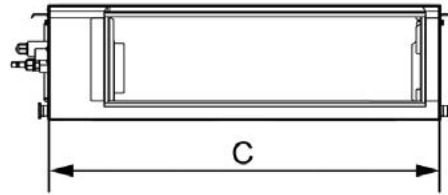

- ① Electric Box
- ② Gas pipe
- ③ Liquid pipe

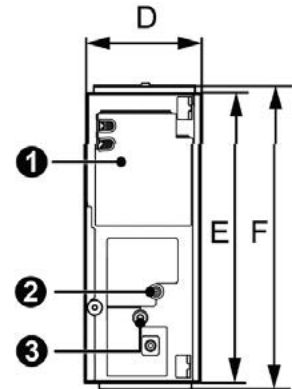

### OUTDOOR UNIT

Unit: inch

LIV30HP230V1R32AO	
DIMENSIONS	
A	36 11/32
B	39 3/8
C	29 3/8
D	14 17/32
E	16 13/16
F	24 1/64
G	15 35/64

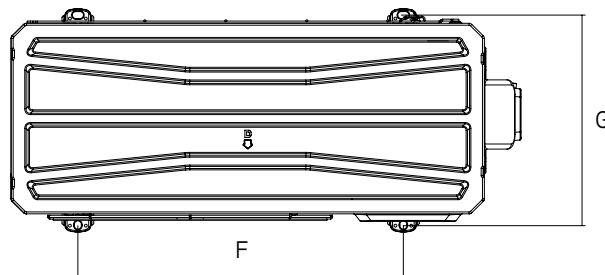
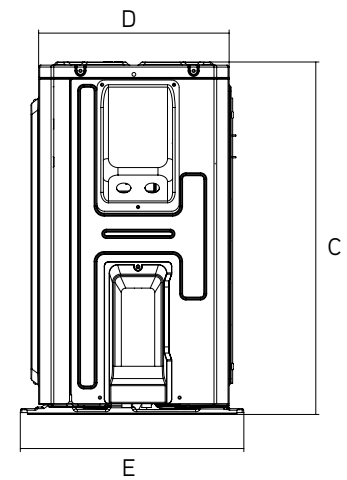
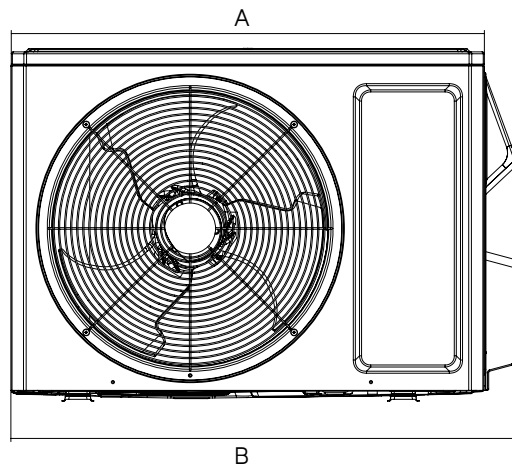

## SUPPLY AND RETURN AIR OPENING DIMENSIONS

### SUPPLY AIR OUTLET

Unit: inch

DUC30HP230V1R32AH	
DIMENSIONS	
A	8-30/64
B	29-9/64

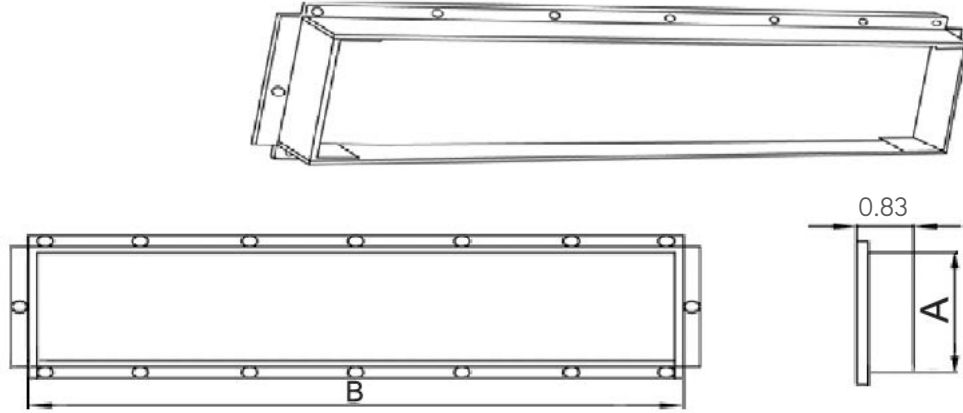

### RETURN AIR INLET

Unit: inch

DUC30HP230V1R32AH	
DIMENSIONS	
C	34-19/64
D	9-7/32



# CLEARANCES

## INDOOR UNIT

Minimum clearance

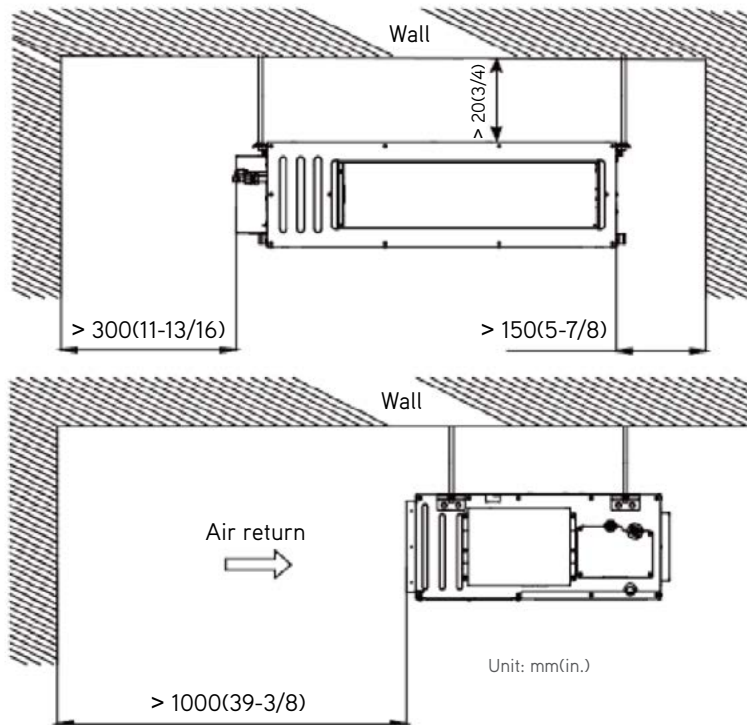

## OUTDOOR UNIT

Minimum clearance

**NOTE:**  
If bottom of the unit is free of airflow obstructions similar to the mounting bracket figure, the clearance to the wall on the back can be reduced to 3 inches.

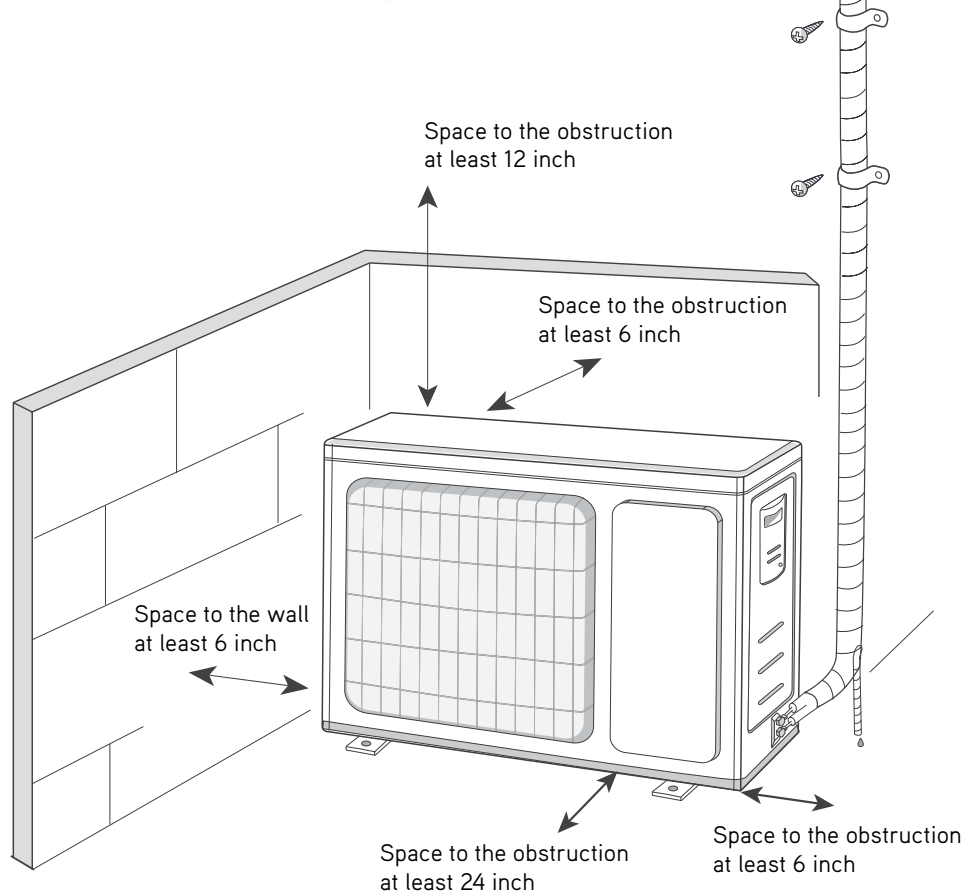

Specifications are subject to change without notice. Manufacturer reserves the right to discontinue or modify specifications or designs without notice or without incurring obligations. All Rights reserved.