



Air comfort for all



OWNER'S MANUAL

Outdoor Unit

MODELS:

FXE30HP230V1R32AO
FXE36HP230V1R32AO
FXE60HP230V1R32AO

Thank you for choosing our product.
Please read this Owner's Manual carefully before
operation and retain it for future reference.

To download an electric version of this manual visit
<https://gree-comfort-dev.web.app/system-documentation/>

To Users

Thank you for selecting Gree product. Please read this instruction manual carefully before installing and using the product, so as to master and correctly use the product. In order to guide you to correctly install and use our product and achieve expected operating effect, we hereby instruct as below:

- (1) This appliance is not intended for use by persons (including children) with reduced physical, sensory or mental capabilities, or lack of experience and knowledge, unless they have been given supervision or instruction concerning use of the appliance by a person responsible for their safety. Children should be supervised to ensure that they do not play with the appliance.
- (2) In order to ensure reliability of product, the product may consume some power under stand-by status for maintaining normal communication of system and preheating refrigerant and lubricant. If the product is not to be used for long, cut off the power supply; please energize and preheat the unit in advance before reusing it.
- (3) Please properly select the model according to actual using environment, otherwise it may impact the using convenience.
- (4) This product can't be installed at corrosive, inflammable or explosive environment or the place with special requirements, such as kitchen. Otherwise, it will affect the normal operation or shorten the service life of the unit, or even cause fire hazard or serious injury. As for above special places, please adopt special air conditioner with anti-corrosive or anti-explosion function.
- (5) If the product needs to be installed, moved or maintained, please contact our designated dealer or local service center for professional support. Users should not disassemble or maintain the unit by themselves, otherwise it may cause relative damage, and our company will bear no responsibilities.
- (6) All the illustrations and information in the instruction manual are only for reference. In order to make the product better, we will continuously conduct improvement and innovation. If there is adjustment in the product, please subject to actual product.

Exception Clauses

Manufacturer will bear no responsibilities when personal injury or property loss is caused by the following reasons:

- (1) Damage the product due to improper use or misuse of the product.
- (2) Alter, change, maintain or use the product with other equipment without abiding by the instruction manual of manufacturer.
- (3) After verification, the defect of product is directly caused by corrosive gas.
- (4) After verification, defects are due to improper operation during transportation of product.
- (5) Operate, repair, maintain the unit without abiding by instruction manual or related regulations.
- (6) After verification, the problem or dispute is caused by the quality specification or performance of parts and components that produced by other manufacturers.
- (7) The damage is caused by natural calamities, bad using environment or force majeure.

Contents

1 Safety Precautions	1
2 Product Introduction	5
2.1 Operating Range	5
2.2 Standard Accessories	5
3 Installation	5
3.1 Installation Preparation	5
3.2 Unit Installation	10
3.3 Electrical Installation	19
3.4 Check after Installation	23
3.5 Test Running	24
4 Maintenance	25
4.1 Failures Not Caused by Faults of the AC	25
4.2 Error Code	27
4.3 Unit Maintenance	29
4.4 Notice on Maintenance	31
5 Qualification of Worker	35
6 Transportation, Marking and Storage for Units that Employ Flammable Refrigerants.....	36
6.1 General	36
6.2 Transport of Equipment Containing Flammable Refrigerants	36
6.3 Marking of Equipment Using Signs	36
6.4 Disposal of Equipment Using Flammable Refrigerants	36
6.5 Storage of Equipment / Appliances	37
6.6 Storage of Packed (Unsold) Equipment	37
7 Information on Servicing	37
7.1 General	37
7.2 Checks to the Area	37

7.3 Work Procedure.....	37
7.4 General Work Area	37
7.5 Checking for Presence of Refrigerant.....	37
7.6 Presence of Fire Extinguisher	38
7.7 No Ignition Sources	38
7.8 Ventilated Area	38
7.9 Checks to the Refrigerating Equipment	38
7.10 Checks to Electrical Devices	39
7.11 Pipe Installation.....	39
8 Sealed Electrical Components shall be Replaced.....	40
9 Intrinsically Safe Components must be Replaced	40
10 Cabling.....	40
11 Detection of Flammable Refrigerants.....	40
12 Removal and Evacuation	41
13 Charging Procedures	42
14 Decommissioning	42
15 Labelling	43
16 Recovery	43

1 Safety Precautions

WARNING

This product can't be installed at corrosive, inflammable or explosive environment or the place with special requirements, such as kitchen. Otherwise, it will affect the normal operation or shorten the service life of the unit, or even cause fire hazard or serious injury. As for above special places, please adopt special air conditioner with anti-corrosive or anti-explosion function.

Improper installation, adjustment, alteration, service, maintenance, or use can cause explosion, fire, electrical shock, or other conditions which may cause death, personal injury, or property damage. Consult a qualified installer, service agency, or your distributor or branch for information or assistance. The qualified installer or agency must use factory--authorized kits or accessories when modifying this product. Refer to the individual instructions packaged with the kits or accessories when installing. Follow all safety codes. Wear safety glasses, protective clothing, and work gloves. Use quenching cloth for brazing operations. Have fire extinguisher available. Read these instructions thoroughly and follow all warnings or cautions included in literature and attached to the unit. Consult local building codes and National Electrical Code (NEC) for special requirements. Recognize safety information. This is the safety--alert symbol .

When you see this symbol on the unit and in instructions or manuals, be alert to the potential for personal injury. Understand these signal words: **DANGER**, **WARNING**, **CAUTION** and **NOTICE**. These words are used with the safety--alert symbol.

DANGER

Indicates a hazardous situation that, if not avoided, will result in death or serious injury.

WARNING

Indicates a hazardous situation that, if not avoided, could result in death or serious injury.

CAUTION

Indicates a hazardous situation that, if not avoided, may result in minor or moderate injury.

NOTICE

Indicates important but not hazard-related information, used to indicate risk of property damage.



Appliance filled with flammable magas R32.



Before install the appliance, read the installation manual first.



Before use the appliance, read the owner's manual first.



Before repair the appliance, read the service manual first.

⚠ WARNING

Do not use means to accelerate the defrosting process or to clean, other than those recommended by the manufacturer.

The appliance shall be stored in the room without continuously operating ignition sources (for example: open flames, an operating gas appliance or an operating electric heater.)

Do not pierce burn.

Be aware that refrigerant may not contain an odor.

⚠ WARNING

Electrical shock hazard:

Failure to follow this warning could result in personal injury or death.

Before installing, modifying, or servicing system, main electrical disconnect switch must be in the OFF position. There may be more than 1 disconnect switch. Lock out and tag switch with a suitable warning label.

⚠ WARNING

- | |
|--|
| (1) The air conditioner should be grounded to avoid electric shock. Do not connect the ground wire to gas pipe, water pipe, lightning arrester or telephone wire. |
| (2) The appliance shall be stored in a well-ventilated area where the room size corresponds to the room area as specified for operation. |
| (3) The appliance shall be stored in a room without continuously operating open flames (for example an operating gas appliance) and ignition sources (for example an operating electric heater). |
| (4) According to federal/state/local laws and regulations, all packages and transportation materials, including nails, metal or wooden parts, and plastic packing material, must be treated in a safe way. |

⚠ WARNING

- (1) Please install according to this instruction manual. Installation must be performed in accordance with the requirement of NEC and CEC by authorized personnel only.
- (2) Any person who is involved with working on or breaking into a refrigerant circuit should hold a current valid certificate from an industry-accredited assessment authority, which authorizes their competence to handle refrigerants safely in accordance with an industry recognized assessment specification.
- (3) Servicing shall only be performed as recommended by the equipment manufacturer.
- (4) The appliance shall be installed in accordance with national wiring regulations.
- (5) The fixed wires connecting to the appliance must be configured with all-pole disconnection device under voltage grade III according to wiring rules.
- (6) Air conditioner should be stored with protective measures against mechanical damage caused by accident.
- (7) If the installation space for air conditioner pipe is too small, adopt a protective measure to prevent the pipe from physical damage.
- (8) During installation, use the specialized accessories and components, otherwise water leakage, electric shock or fire hazard may occur.
- (9) Please install the air conditioner in a secure place that can withstand the weight of air conditioner. Insecure installation may cause the air conditioner falling down and lead to injury.
- (10) Be sure to adopt independent power circuit. If the power cord is damaged, it must be repaired by the manufacturer, service agent or other professional agents.
- (11) The air conditioner can be cleaned only after it is turned off and power-disconnected, otherwise electric shock may occur.
- (12) The air conditioner is not intended to be cleaned or maintained by children without supervision.
- (13) Do not alter the setting of pressure sensor or other protective devices. If the protective devices are short-circuited or changed against rules, fire hazard or even explosion may occur.
- (14) Do not operate the air conditioner with wet hands. Do not wash or sprinkle water on the air conditioner, otherwise malfunction or electric shock will occur.
- (15) Do not dry the filter with naked flame or an air blower; otherwise the filter will be out of shape.
- (16) If the unit is to be installed in a small space, please adopt protective measures to prevent the concentration of refrigerant from exceeding the allowable safety limit; excessive refrigerant leakage may lead to explosion.
- (17) When installing or re-installing the air conditioner, please keep the refrigerant circuit away from substances other than the specified refrigerant, such as air. Any presence of foreign substances will cause abnormal pressure change or even explosion, resulting in injury.
- (18) The heat pump and the furnace cannot turn on the heating function at the same time, otherwise it will cause safety failure.

NOTICE

- (1) Do not put a finger or other objects into the air inlet or return air grill.
- (2) Please adopt safety protection measures before touching the refrigerant pipe; otherwise your hands may be hurt.
- (3) Please arrange the drain pipe according to the instruction manual.
- (4) Never stop the air conditioner by directly cutting off the power.
- (5) Please select the proper copper pipe according to the requirement for pipe thickness.
- (6) Never install the air conditioner in the following places:
 - a) Places with oil smoke or volatile liquid: plastic parts may deteriorate and fall off or even cause water leakage.
 - b) Places with corrosive gas: copper pipe or the welding parts may be corroded and cause refrigerant leakage.
- (7) Adopt proper measures to protect the outdoor unit from small animals because they may damage the electric components and cause malfunction of the air conditioner.

NOTICE



- (1) If thermostat is to be used, it should be connected first before powering up the unit, otherwise the thermostat may not be able to use.
- (2) Only use soft dry cloth or slightly wet cloth with neutral detergent to clean the casing of the air conditioner.
- (3) Before operating the unit under low temperature, connect it to power for 8 hours. If it is stopped for a short time, for example, one night, do not cut off the power (This is to protect the compressor).
- (4) In order to ensure the reliability of the compressor, the unit force the compressor run for at least 6 minutes every time the compressor turns on, regardless of the room temperature. Therefore, it is necessary to select a thermostat having the minimum run time for the compressor or delaying a few minutes to turn the indoor unit off after the outdoor unit is shut down or stopped at the temperature point, in order to avoid that the indoor unit is turned off by the thermostat while the out unit is running which can result in the malfunction of the air conditioner.
- (5) In order to avoid the abnormality of the unit caused by the high temperature of the pipe, it is forbidden to use gas auxiliary when the outdoor unit is turned on.
- (6) Because the cut-off valve is connected by welding after sale, there is a hidden danger of O-ring in the cut-off valve that will affect the sealing leakage. Therefore, when welding the connecting pipe, the valve body of the cut-off valve should be wrapped with wet cloth for protection.
- (7) This product cannot be used in combination with other products, otherwise it may cause performance, reliability and safety problems.

2 Product Introduction

2.1 Operating Range

—	Cooling	Heating
Outdoor temperature	5°F(-15°C)~118.4°F (48°C)	5°F(-15°C)~75.2°F (24°C)

2.2 Standard Accessories

Outdoor unit accessories				
No.	Name	Appearance	Q'ty	Usage
1	Drain plug		3	To plug the unused drain hole
2	Drainage connector	 or 	1	To connect with the hard PVC drain pipe

3 Installation

3.1 Installation Preparation

3.1.1 Selection of Installation Location

 WARNING
(1) The unit must be installed where strong enough to withstand the weight of the unit and fixed securely, otherwise the unit would topple or fall off.
(2) Install the air conditioner at a place where the inclination is less than 5°.
(3) Do not install where there is the danger of combustible gas leakage.
(4) Do not install the unit at a place with leakage of inflammable gas.

Selection of installation location for outdoor unit (Select a location pursuant to the following condition).

- (1) Noise and air flow produced by the outdoor unit will not disturb the neighbors.
- (2) Select a location that is safe and away from animals and plants. If not, please add safety fences to protect the unit.
- (3) Install at a place with good ventilation. Make sure the outdoor unit stays at a well-ventilated place with no obstacles nearby that may obstruct the air inlet and outlet.
- (4) The installation location should be able to withstand the weight and vibration of outdoor unit and allow the installation to be carried out safely.
- (5) Avoid installing at a place with leakage of inflammable gas, oil smoke or corrosive gas.

- (6) Keep it away from strong wind because strong wind will affect the outdoor fan and lead to insufficient air flow volume and thus affecting the unit's performance.
- (7) Away from any object that may get the air conditioner generating noise.
- (8) Install the outdoor unit at a place where condensate can be easily drained.

3.1.2 Unit Dimension

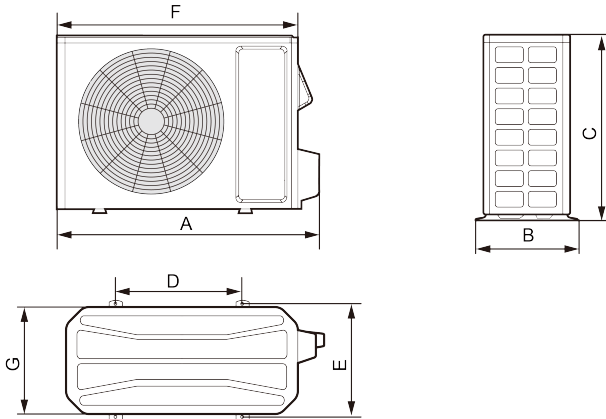

Unit: inch(mm)

Model	Dimensions						
	A	B	C	D	E	F	G
FXE30HP230V1R32AO	39-3/8	16-13/16	29-3/8	24	15-9/16	36-1/4	14-9/16
FXE36HP230V1R32AO	(1000)	(427)	(746)	(610)	(396)	(920)	(370)

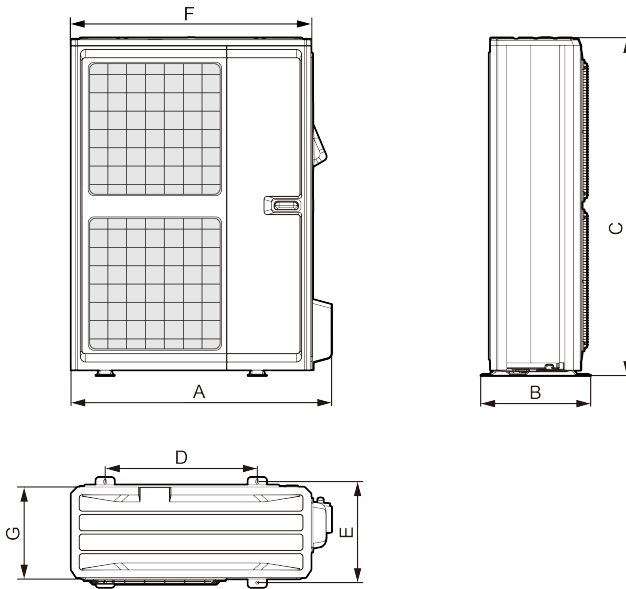

Unit: inch(mm)

Model \ Dimensions	A	B	C	D	E	F	G
FXE60HP230V1R32AO	38-1/2 (978)	16-1/4 (412)	49-5/8 (1260)	22-7/16 (570)	14-7/8 (378)	35-7/16 (900)	13-3/8 (340)

NOTE: The indoor unit models that can be matched with the outdoor unit can be found on the AHRI website.

This unit is equipped with a leak detection system for safety. For leak detection to be effective, the unit must be electrically powered at all times after installation, other than when servicing.

This unit is equipped with electrically powered safety measures. For the safety measures to be effective, the unit must be electrically powered at all times after installation, other than when servicing.

3.1.3 Diagram of Unit Installation Space and Location

Diagram of installation space and location for outdoor unit (Notice: for best performance of the outdoor unit, make sure its installation space conforms to the following installation dimensions).

1) When one outdoor unit is to be installed.

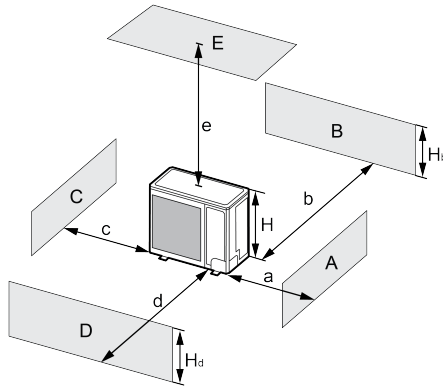

A~E	H_b H_d H		(INCH)				
			a	b	c	d	e
B	—		—	$\geq 3 \frac{7}{8}$	—	—	—
A,B,C,	—		$\geq 11 \frac{3}{4}$	$\geq 3 \frac{7}{8}$	$\geq 3 \frac{7}{8}$	—	—
B,E	—		—	$\geq 3 \frac{7}{8}$	—	—	$\geq 39 \frac{3}{8}$
A,B,C,E	—		$\geq 11 \frac{3}{4}$	$\geq 5 \frac{7}{8}$	$\geq 5 \frac{7}{8}$	—	$\geq 39 \frac{3}{8}$
D	—		—	—	—	$\geq 39 \frac{3}{8}$	—
D,E	—		—	—	—	$\geq 39 \frac{3}{8}$	$\geq 39 \frac{3}{8}$
B,D	$H_b < H_d$	$H_d > H$	—	$\geq 3 \frac{7}{8}$	—	$\geq 39 \frac{3}{8}$	—
	$H_b > H_d$	$H_d < H$	—	$\geq 3 \frac{7}{8}$	—	$\geq 39 \frac{3}{8}$	—
B,D,E	$H_b < H_d$	$H_b \leq 1/2H$	—	$\geq 9 \frac{7}{8}$	—	$\geq 78 \frac{3}{4}$	$\geq 39 \frac{3}{8}$
		$1/2H < H_b \leq H$	—	$\geq 9 \frac{7}{8}$	—	$\geq 78 \frac{3}{4}$	$\geq 39 \frac{3}{8}$
		$H_b > H$	Prohibited				
	$H_b > H_d$	$H_d \leq 1/2H$	—	$\geq 3 \frac{7}{8}$	—	$\geq 78 \frac{3}{4}$	$\geq 39 \frac{3}{8}$
		$1/2H < H_d \leq H$	—	$\geq 5 \frac{7}{8}$	—	$\geq 78 \frac{3}{4}$	$\geq 39 \frac{3}{8}$
		$H_d > H$	Prohibited				

2) When two or more outdoor units are to be installed side by side.

Unit: mm

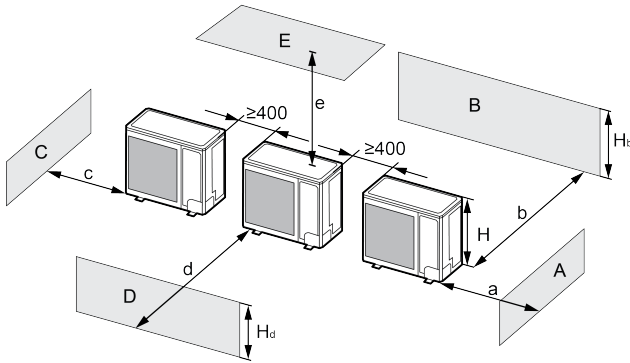

A~E	H _b H _d H		(INCH)				
			a	b	c	d	e
A,B,C	—		$\geq 11 \frac{3}{4}$	$\geq 11 \frac{3}{4}$	$\geq 39 \frac{3}{8}$	—	—
A,B,C,E	—		$\geq 11 \frac{3}{4}$	$\geq 11 \frac{3}{4}$	$\geq 39 \frac{3}{8}$	—	$\geq 39 \frac{3}{8}$
D	—		—	—	—	$\geq 78 \frac{3}{4}$	—
D,E	—		—	—	—	$\geq 78 \frac{3}{4}$	$\geq 39 \frac{3}{8}$
B,D	H _b < H _d	H _d > H	—	$\geq 11 \frac{3}{4}$	—	$\geq 78 \frac{3}{4}$	—
		H _b > H _d	—	$\geq 9 \frac{7}{8}$	—	$\geq 78 \frac{3}{4}$	—
			$1/2H < H_d \leq H$	—	$\geq 11 \frac{3}{4}$	—	$\geq 98 \frac{3}{8}$
B,D,E	H _b < H _d	H _b ≤ 1/2H	—	$\geq 11 \frac{3}{4}$	—	$\geq 78 \frac{3}{4}$	$\geq 39 \frac{3}{8}$
		$1/2H < H_b \leq H$	—	$\geq 11 \frac{3}{4}$	—	$\geq 98 \frac{3}{8}$	$\geq 39 \frac{3}{8}$
		H _b > H	Prohibited				
	H _b > H _d	H _d ≤ 1/2H	—	$\geq 9 \frac{7}{8}$	—	$\geq 98 \frac{3}{8}$	$\geq 39 \frac{3}{8}$
		$1/2H < H_d \leq H$	—	$\geq 11 \frac{3}{4}$	—	$\geq 98 \frac{3}{8}$	$\geq 39 \frac{3}{8}$
		H _d > H	Prohibited				

3) When outdoor units are installed in rows.

Unit: mm

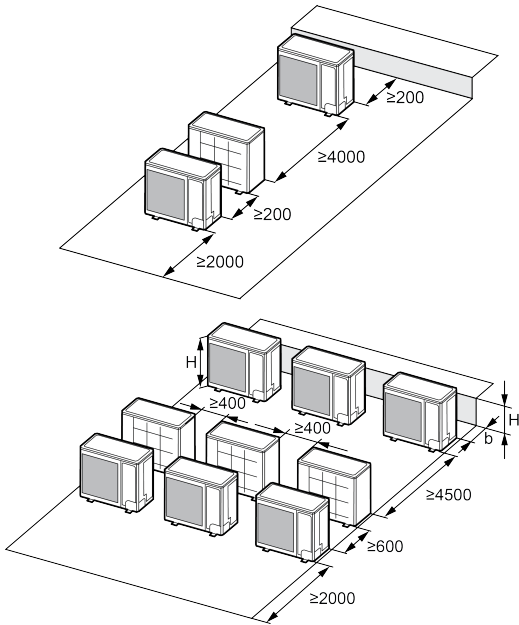

H_b H	(INCH)
$H_b \leq 1/2H$	$b \geq 9 \frac{7}{8}$
$1/2H < H_b \leq H$	$b \geq 11 \frac{3}{4}$
$H_b > H$	Prohibited

3.2 Unit Installation

NOTICE
<p>(1) The outdoor unit does not have a TXV (thermal expansion valve), please make sure there is a throttling valve (which throttles the unit when it operates in cooling mode and opens fully when it operates in heating mode) in the indoor unit (air handler or A coil).</p>
<p>(2) For areas with frequent snowfall, please clean up the snow in time to avoid covering unit. The unit installed in areas expecting snow are suggested to be raised with support frames If possible, avoid locations that are likely to accumulate snow. if not possible, a snow guard should be installed on the unit to prevent accumulation of snow on the top of the unit.</p>

3.2.1 Outdoor Unit Installation

- (1) If the outdoor unit is installed on a solid ground such as concrete, use M10 screw bolts and nuts to secure the unit and make sure the unit stands erect and level.
- (2) If it vibrates and causes noise, please add rubber cushion between the outdoor unit and the installation base. In order to avoid the influence of outdoor unit noise, the outdoor unit should be away from the bedroom, window and other places.
- (3) When the outdoor unit is in heating or defrosting, it needs to drain water. When installing the drain pipe, plug the accompanied drainage connector to the drainage hole on the chassis of the outdoor unit. Then connect a drain hose to the drainage connector (If drainage connector is used, the outdoor unit should be at least 10cm from the installation ground. See the following figures).

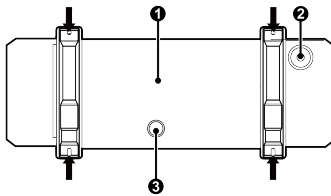

- ❶ Bottom
- ❷ Drain cap
- ❸ Drain pipe mounting hole

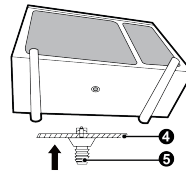

- ❹ Chassis
- ❺ Drain connection

- (4) Do not install the air conditioner where water, ice or snow from overhang or roof may damage or flood the unit.

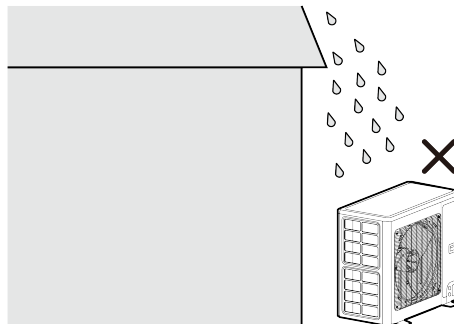

- (5) Do not install the air conditioner in a corrosive environment, otherwise it may shorten the life, or negatively affect the performance of the unit.
- (6) Installation requirements in snowy areas:
 - 1) Install the air conditioner on a stand which more than 20 in.(500mm) higher than the expected snow fall to prevent it from being covered by snow.
 - 2) Attach snow hood and snow guard, see the following figures.
 - 3) Do not install the air conditioner at a place where a snowdrift is generated.
 - 4) Remove the air inlet grille to prevent snow from accumulating on it.
 - 5) Plugs and drainage connector are not recommended.

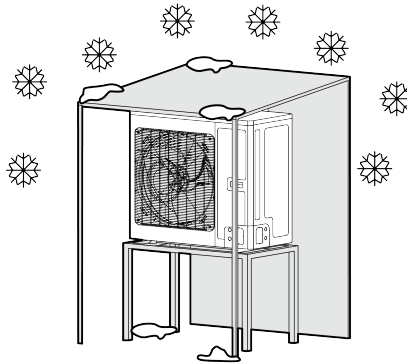

3.2.2 Connection Pipe Installation

3.2.2.1 Installation Notice and Requirement on Connection Pipe

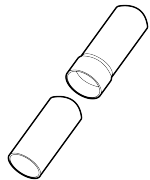

Line set size matches service valve connector



Do not crimp service valve connector when pipe is smaller than connector

Installation method: Connect the connection pipes first to the unit. When bending a connection pipe, be careful not to damage the pipe. Do not over-tighten the screw nut, otherwise leakage will occur. Besides, the outside of connection pipe should be added with a layer of insulating cotton to protect it from mechanical damage during installation, maintenance and transportation.

Model \ Item	Size of fitting pipe(inch)		Maximum pipe length feet(m)	Biggest drop between indoor and outdoor units feet(m)
	Liquid pipe	Gas pipe		
FXE30HP230V1R32AO FXE36HP230V1R32AO FXE60HP230V1R32AO	Φ3/8	Φ3/4	98.4(30)	98.4(30)

Connection pipe should adopt water-proof insulating material. Its wall thickness should be 0.5-1.0mm and the pipe wall should be able to withstand 6.0MPa. The longer the connection pipe is the worse cooling and heating performance it has.

3.2.2.2 Pipe Flaring

- (1) Cut the connection pipe with a pipe cutter.
- (2) The mouth of connection pipe should face downward. Remove burrs with the cut surface so that the chips do not enter the pipe.
- (3) Remove the cut-off valve of outdoor unit and take out the flare nut from the bag of indoor unit accessories. Then fit the flare nut on the pipe and use a flaring tool to flare the mouth of connection pipe.
- (4) Check whether the flaring part has cracked. (See the figure below).
- (5) If you replace the outdoor unit, you need to welded an additional dry filter at the gas pipe.

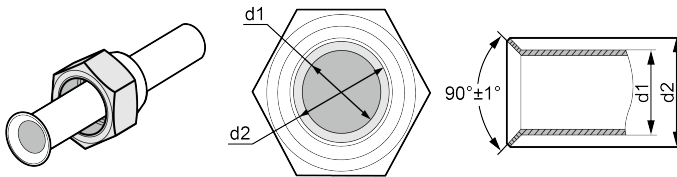

3.2.2.3 Pipe Bending

- (1) The pipes are shaped by your hands. Be careful not to collapse them.

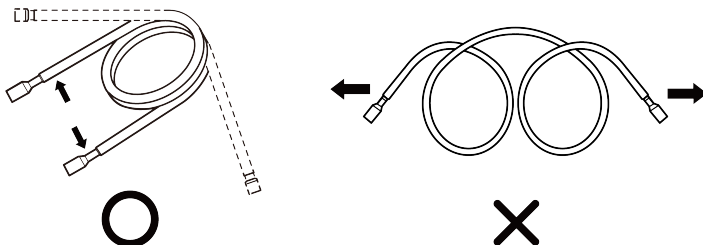

- (2) Do not bend the pipes in an angle more than 90°.
- (3) If the pipe is repeatedly bent or extended, it will become hard and difficult to be bent or extended. So do not bend or extend the pipe for more than 3 times.
- (4) When bending the pipe, do not bend it excessively, otherwise it will get broken. As shown beside, use a sharp cutter to cut the heat insulating pipe and bend it after the pipe is exposed. After bending, place the heat insulating pipe back on the pipeline and fix it with adhesive tape.

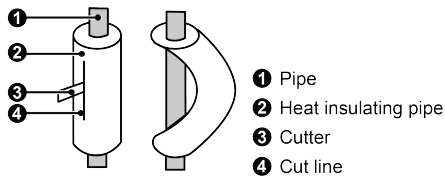

3.2.2.4 Connection Pipe of the Units

NOTICE

- | |
|---|
| (1) Connect the pipe to the unit. Please follow the instructions stated in the figures below. Use both spanner and torque wrench. |
| (2) When connecting the tapered screw nut, first apply chilled machine oil on its inner and outer surface and then screw it up for 3~4 circles. |
| (3) Confirm the tightening torque by referring to the following table (If the screw nut is over-twisted, it may be damaged and cause leakage). |
| (4) Check whether gas leakage occurs to the connection pipe and then apply thermal insulation, as shown below. |
| (5) Wind sponge around the joint of gas pipe and heat insulation sheath of gas collecting pipe. |
| (6) Be sure to connect gas pipe after liquid pipe is connected. |
| (7) Be sure to have insulation for gas pipe. Insulation for liquid pipe is optional. |

3.2.2.4.1 Screw Connection

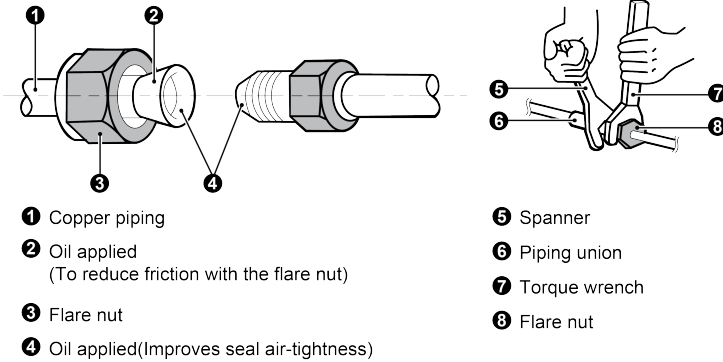

- ❶ Copper piping
- ❷ Oil applied
(To reduce friction with the flare nut)
- ❸ Flare nut
- ❹ Oil applied(Improves seal air-tightness)
- ❺ Spanner
- ❻ Piping union
- ❼ Torque wrench
- ❽ Flare nut

Pipe diameter (inch)	Tightening torque (FT-LB)
Φ1/4	11-22
Φ3/8	25-29
Φ1/2	33-36
Φ5/8	44-47
Φ3/4	51-55
Φ7/8	59-62

3.2.3 Connection Pipe Vacuum Pumping and Leak Detection

3.2.3.1 Vacuum Pumping

NOTICE

- (1) Make sure the outlet of vacuum pump is away from fire source and is well-ventilated.
- (2) Before vacuum pumping, make sure the unit cut-off valves are closed.
 - (1) Remove the caps of the liquid valve, gas valve and also the service port.
 - (2) Connect the hoses at the low pressure and high pressure sides of the manifold valve assembly to the service ports of the unit's gas valve and liquid valve, and meanwhile the gas and liquid valves should be kept closed in case of refrigerant leak.
 - (3) Connect the hose used for evacuation to the vacuum pump.
 - (4) Open the switch at the lower pressure side of the manifold valve assembly and start the vacuum pump. Meanwhile, the switch at the high pressure side of the manifold valve assembly should be kept closed, otherwise evacuation would fail.

(5) The evacuation duration depends on the unit's capacity, generally.

Model	Time(min)
FXE30HP230V1R32AO FXE36HP230V1R32AO FXE60HP230V1R32AO	45

And verify if the pressure gauge at the low pressure side of the manifold valve assembly reads -0.1MPa, if not, it indicates there is leak somewhere. Then, close the switch fully and then stop the vacuum pump.

- (6) Wait for 10min to see if the system pressure can remain unchanged. During this time, the reading of the pressure gauge at the low pressure side can not be larger than 0.005MPa.
- (7) Slightly open the liquid valve and let some refrigerant go to the connection pipe to balance the pressure inside and outside of the connection pipe, so that air will not come into the connection pipe when removing the hose. Note that the gas and liquid valve can be opened fully only after the manifold valve assembly is removed.
- (8) Place back the caps of the liquid valve, gas valve and also the service port.

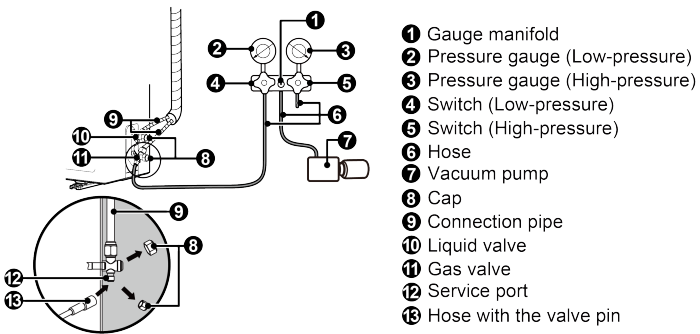

NOTICE

For large-size units, there are maintenance ports for liquid valve and gas valve. During evacuation, you may connect the two hoses of the branch valve assembly to the maintenance ports to speed up the evacuation.

3.2.4 Refrigerant Adding

See the following table for the amount of additional refrigerant.

Model \ Item	Standard pipe length	Unnecessary charge pipe length	Additional refrigerant amount for extra pipe
FXE30HP230V1R32AO FXE36HP230V1R32AO FXE60HP230V1R32AO	7.5m	≤9.5m	20g/m

NOTE: Compliance with relevant national gas regulations: Indoor refrigerant joints made on site shall be tested for tightness. The test method shall be leak detection with equipment with a sensitivity of 5g/year or higher at a minimum of 0.25 times the maximum allowable pressure. There shall be no leakage detection.

3.2.5 Installation of Drain Pipe

3.2.5.1 Outdoor Side Drainage Pipe

- (1) If the outdoor unit is underneath the indoor unit, arrange the pipeline according to the following diagram.
 - 1) Drain hose should be placed on the ground and its end should not be immersed into water. The whole pipeline should be supported and fixed onto the wall.
 - 2) Wind the insulating tape from bottom to top.
 - 3) The whole pipeline should be wound with insulating tape and fixed onto the wall with saddles.

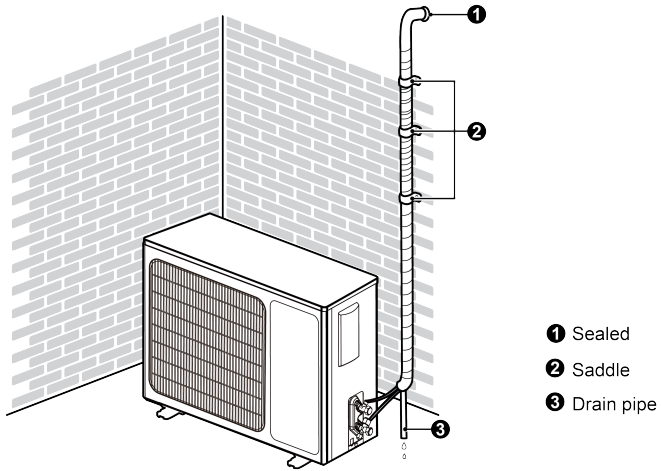

- (2) If the outdoor unit is above the indoor unit, arrange the pipeline according to the following diagram.
- 1) Wind the insulating tape from bottom to top.
 - 2) The whole pipeline should be wound together to avoid water returning to the room.
 - 3) Use saddles to fix the whole pipeline onto the wall.

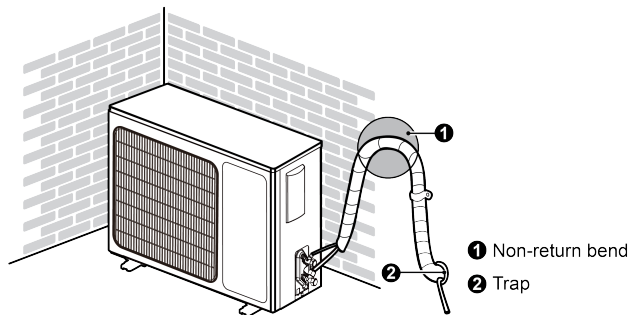

3.3 Electrical Installation

3.3.1 Requirement and Notice on Electrical Installation

WARNING

The electrical installation for the air conditioner should observe the following requirements:

- ①. The electrical installation must be conducted by professionals in compliance with local laws and regulations and the instructions in this manual. The electric circuit must be equipped with a circuit breaker and air switch both with sufficient capacity.
- ②. The unit's operating power must be within the nominal range stated in the instruction manual. Use a specialized power circuit for the air conditioner. Do not draw power from another power circuit.
- ③. The air conditioner circuit should be at least 1.5m away from any inflammable surface.
- ④. The external power cords, the communication wires and outdoor unit must be effectively fixed.
- ⑤. The external power cords, the communication wires and outdoor unit can't directly contact any hot objects. For example: they must not contact chimney pipes, warm gas pipes or other hot objects.
- ⑥. The external power cords, and the communication wires and outdoor unit must not be squeezed. Never pull, stretch or bend the wires.
- ⑦. The external power cords, the communication wires and outdoor unit must not collide with any metal beam or edge on the ceiling, or touch any metal burrs or sharp metal edge around.
- ⑧. Connect wires correspondingly by referring to the circuit diagram labeled on the unit or electric box. Screws must be tightened up. Slipped screws must be replaced by specialized flat-head screws.
- ⑨. Wiring terminals should be connected firmly to the terminal board. Loose connection is forbidden.
- ⑩. The wire gauge of power cords should be large enough. Damaged power cords or other wires must be replaced by specialized wires. Wiring work must be done according to national wiring rules and regulations.
- ⑪. This outdoor unit has a heating four-way valve.

3.3.2 Electrical Parameters

Model	Power supply	Fuse capacity (A)	Maximum over-current protection (A)	Minimum circuit ampacity (A)
FXE30HP230V1R32AO	208/230V 1Ph-60Hz	25	25	21.6
FXE36HP230V1R32AO	208/230V- 1Ph-60Hz	25	25	21.6
FXE60HP203V1R32AO	208/230V 1Ph-60Hz	40	40	35.5

NOTE: All wires must go through the tube.

3.3.3 Connection of Power Cords and Communication Wires

- (1) For solid wires (as shown below):
 - 1) Use wire cutters to cut off the wire end and then peel away about 25mm of the insulation layer.
 - 2) Use a screwdriver to unscrew the terminal screw on the terminal board.
 - 3) Use nippers to bend the solid wire into a ring that fits the terminal screw.
 - 4) Form a proper ring and then put it on the terminal board. Use a screwdriver to tighten up the terminal screw.
- (2) For strand wires (as shown below):
 - 1) Use wire cutters to cut off the wire end and then peel away about 10mm of the insulation layer.
 - 2) Use a screwdriver to unscrew the terminal screw on the terminal board.
 - 3) Use a round terminal fastener or clamp to fix the round terminal firmly on the peeled wire end.
 - 4) Locate the round terminal conduit. Use a screwdriver to replace it and tighten up the terminal screw (as shown below).

Unit: mm(inch)

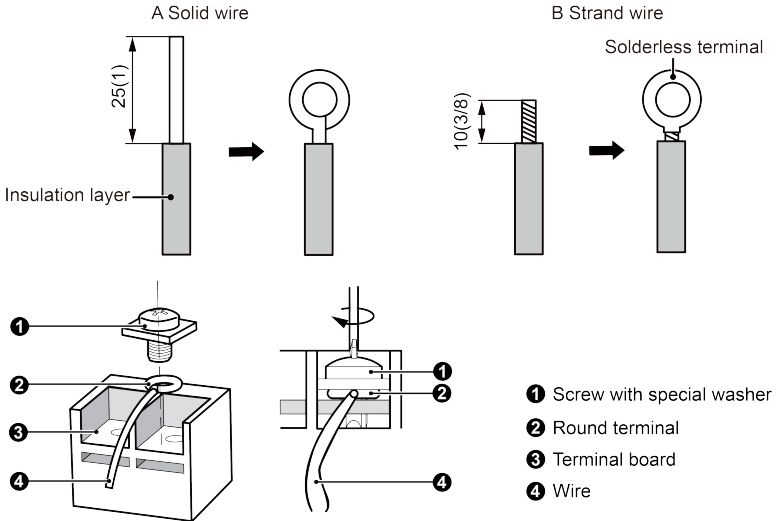

(3) How to connect the communication wires and power cords.

Lead the communication wires and power cords through the insulation tube (as shown in the following figure).

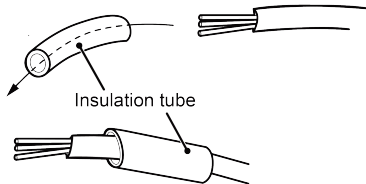

⚠ WARNING
(1) Before working, please check whether the units are powered on.
(2) Wrong wire connection may burn the electrical components.
(3) Connect the wires firmly to the wiring box. Incomplete installation may lead to fire hazard.
(4) Ground wire should be connected.

Electrical wiring of outdoor units

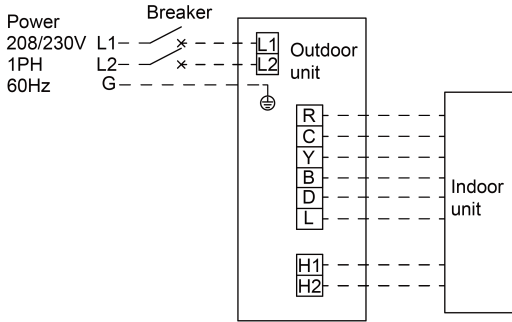

FXE30HP230V1R32AO FXE36HP230V1R32AO, FXE60HP230V1R32AO
24V mode wiring

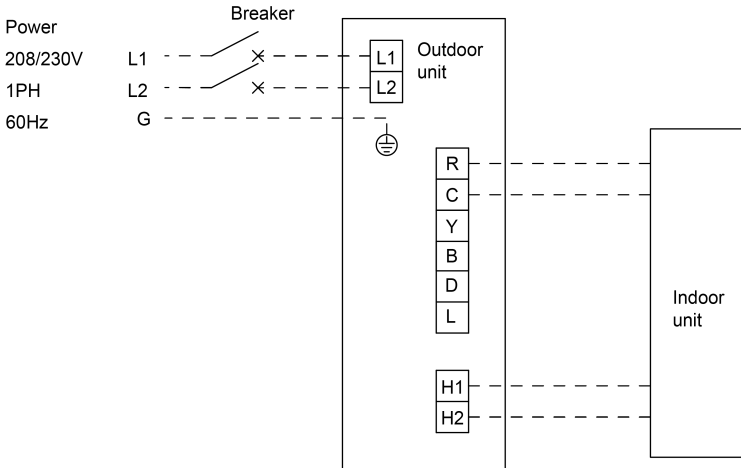

FXE30HP230V1R32AO, FXE36HP230V1R32AO,FXE60HP230V1R32AO
RS485 mode wiring

NOTE: Y means Compressor control signal.

B which is energized under the heating mode means 4-way valve control signal.

D means defrosting signal.

R means 24V AC power supply.

C means 24V common.

L means refrigerant leakage protection signal.

RS485 mode wiring is not connected to Y, B, D, L.

24V mode wiring requires all connections.

NOTE: When outdoor defrosts, D of outdoor unit will send 24V signal to avoid cold winds.

NOTE: As for the indoor unit which do not include D, there is no need to connect the D terminals.

NOTE: L must be connected and connected to the indoor machine.

⚠ WARNING	
(1)	High and low voltage wires should be led out from holes in the handle.
(2)	Do not bundle up the communication wires or lay them side by side, otherwise errors will occur.
(3)	High and low voltage wires should be secured separately.
(4)	Use screws to tighten up the communication wires and power cords of the units on the terminal board. Wrong connection may lead to fire hazard.
(5)	If the communication wires of the units and power cords are not correctly connected, the air conditioner may get damaged.
(6)	Ground the units through connecting the ground wire.
(7)	The units should comply with applicable local and national rules and regulations on power consumption.
(8)	When connecting the power cords, make sure the phase sequence of the power supply matches with the corresponding terminals, otherwise the compressor will get reversed and operate abnormally.

Schematic diagram of the engineering routing:

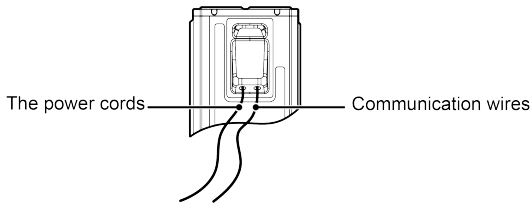

3.4 Check after Installation

Check Items after Installation

Check items	Possible events due to improper installation
Is the main body installed securely?	The unit may fall down, vibrate or produce noise.
Did you do water leakage test?	Cooling capacity may become unsatisfactory.
Is the unit well insulated from heat?	Condensate, water drops may occur.
Does water drainage go well?	Condensate, water drops may occur.
Is the voltage consistent with that	The unit may fail or its components may get

Check items	Possible events due to improper installation
stated on the nameplate?	burned.
Are the wires and pipes installed correctly?	The unit may fail or its components may get burned.
Has the unit been safely grounded?	Risk of electric leakage.
Do the specifications of wires comply with the requirement?	The unit may fail or its components may get burned.
Is there any obstacle blocking the air inlet and outlet of the units?	Cooling capacity may become unsatisfactory.
Have you recorded the length of refrigerant pipe and the refrigerant charging amount?	The refrigerant charging amount can't be controlled.

3.5 Test Running

Preparation before connecting the power:

- (1) Power must not be connected if the installation work is not completed.
- (2) Control circuit is correct and all the wires are firmly connected.
- (3) Cut-off valves of the gas pipe and liquid pipe are open.
- (4) The inside of the unit and the duct of indoor unit should be clean. Take irrelevant objects out if there is any.
- (5) After checking, re-install the front side plate.

Operation after connecting the power:

- (1) If all the above works are finished, power on the unit. Otherwise, it is forbidden to power on the unit.
- (2) If the outside temperature is more than 30°C, heating mode can't be enabled.
- (3) Before test operation, make sure unit is power on and compressor has been preheated for more than 8 hours. Touch the unit to check whether it's normally preheated. Start test operation after unit is normally preheated, otherwise compressor might be damaged. Debugging must be performed by professional technicians or under the guide of professional technicians.
- (4) Make sure the units can run normally.
- (5) If there's sound of liquid shock when the compressor is running, then stop the air conditioner immediately. Wait until the electric heating belt is heated enough, and then restart the air conditioner.

NOTICE

- ①. If you use thermostat to turn off the unit and then immediately turn the unit on again, compressor will need 3min to restart. Even if you press “ON/OFF” button on the thermostat, it won’t be started up right away.
- ②. If there’s no display on the thermostat, it’s probably because the connection wires between the units and the thermostat are not connected. Please check again.

4 Maintenance

4.1 Failures Not Caused by Faults of the AC

If your air conditioner fails to function normally, please first check the following items before maintenance:

Problem	Cause	Corrective measure
The air conditioner can't run.	If you turn off the unit and then immediately turn it on, in order to protect the compressor and avoid system overload, compressor will delay running for 3min.	Please wait for a while.
	Wire connection is wrong.	Connect wires according to the wiring diagram.
	Fuse or circuit breaker is broken.	Replace the fuse or switch on the circuit breaker.
	Power failure.	Restart after power is resumed.
	Power plug is loose.	Re-insert the power plug.
Bad cooling or heating effect.	Air inlet and outlet of the units have been blocked.	Clear the obstacles and keep the room for the units well ventilated.
	Improper temperature setting	Reset a proper temperature.
	Fan speed is too low.	Reset a proper fan speed.
	Air flow direction is not right.	Change the direction of air louvers.
	Doors or windows are open.	Close them.
	Exposed under direct sunshine.	Put on curtains or louvers in front of the windows.
	Too many heat sources in the room.	Remove unnecessary heat sources.
	Filter is blocked or dirty.	Send for a professional to clean the filter.
Air inlets or outlets of the units are blocked.	Clear away obstacles that are blocking the air inlets and outlets of the units.	

The following situations are not operation failures.

Problem	Time of occurrence	Cause
Mist comes from the air conditioner.	During operation.	If the unit is running under high humidity, the wet air in the room will be quickly cooled down.
The air conditioner generates some noise.	System switches to heating mode after defrosting.	Defrosting process will generate some water, which will turn to water vapor.
	The air conditioner is buzzing at the beginning of operation.	Thermostat will be buzzing when it starts working. The noise will become weak 1min later.
Dust comes from the air conditioner.	When the unit is turned on, it purrs.	When the system is just started, the refrigerant is not stable. About 30s later, the purr of the unit becomes low.
	About 20s after the unit first enables the heating mode or there is refrigerant brushing sound when defrosting under heating.	It's the sound of 4-way valve switching direction. The sound will disappear after the valve changes its direction.
	There is hissing sound when the unit is started or stopped and a slight hissing sound during and after operation.	It's the sound of gaseous refrigerant that stops flowing and the sound of drainage system.
	There is a sound of crunching during and after operation.	Because of temperature change, front panel and other components may be swelled up and cause abrasion sound.
	There is a hissing sound when the unit is turned on or suddenly stopped during operation or after defrosting.	Because refrigerant suddenly stops flowing or changes the flow direction.
	The unit starts operation after being unused for a long time.	Dust inside the units come out together with the air.
The air conditioner generates some smell.	During operation.	The room smell or the smell of cigarette comes out through the units.

NOTICE

Check the above items and adopt the corresponding corrective measures. If the air conditioner continues to function poorly, please stop the air conditioner immediately and contact Gree's authorized local service center. Ask our professional service staff to check and repair the unit.

4.2 Error Code

WARNING

- (1) If abnormal things (for example, awful smell) occur, please stop the unit immediately and disconnect power. Then contact Gree's authorized service center. If the unit continues to run in abnormal situations, it may get damaged and cause electric shock or fire hazard.
- (2) Do not repair the air conditioner by yourself. Improper maintenance will cause electric shock or fire hazard. Please contact Gree's authorized service center and send for professional service staff to repair.

If the LED displayer on mainboard of outdoor unit displays an error code, please refer to the error code meaning stated in the following table.

No.	Error code	Error
1	E1	Compressor high pressure protection
2	E3	Refrigerant lack protection or compressor low pressure protection
3	E4	Compressor air discharge high-temperature protection
4	H4	Overload protection
5	C6	Discharge temperature sensor error
6	F3	Outdoor ambient temperature sensor error
7	e1	High pressure sensor error
8	e3	Low pressure sensor error
9	EE	Memory chip reading and writing failure
10	C4	ODU jumper cap error
11	C3	Condenser temperature sensor error
12	C7	ODU tube temperature sensor error
13	H3	Compressor overload protection
14	E2	Indoor Anti-freezing Protection
15	b2	Overcooler Gaseous Inlet Tube Temperature Sensing Error
16	b3	Overcooler Gaseous Outlet Tube Temperature Sensing Error
17	E6	Internal and external machine communication fault
18	H2	IPM Low Temperature Protection
19	FE	Refrigerant sensor fault
20	EH	Protection of auxiliary electric heating by mistake
21	C1	Indoor environment temperature sensing bag fault
22	C2	Indoor tube temperature sensing bag fault
23	FJ	Indoor air outlet temperature sensing bag fault
24	CA	Evaporator inlet tube temperature sensing bag fault

DC Inverter U-match Series for R32 Unitary Split Air Conditioner

No.	Error code	Error
25	Cb	Evaporator output tube temperature sensing bag fault
26	CJ	Internal jumper cap fault
27	Ab	Drive reset protection (fan drive)
28	EA	Internal refrigerant leakage protection
29	A6	Fan communication failure (fan drive)
30	A8	Module temperature too high (fan driven)
31	A9	Drive sensor fault (fan drive)
32	Ad	Phase loss protection (fan drive)
33	AH	Bus voltage too high (fan drive)
34	AL	Bus voltage too low (fan drive)
35	C8	Driver jumper cap fault
36	U2	Compressor phase-sequence protection
37	LE	The compressor is locked
38	P6	Communication fault between main control and driver
39	P8	Heat sink or IPM module or PFC module over temperature
40	UL	Over-current protection of frequency conversion external fan
41	PL	Bus low-voltage protection
42	PH	Bus high-voltage protection
43	PA	ODU AC current protection
44	H5	IPM module current protection
45	L3	DC fan error
46	HC	PFC overcurrent protection
47	Lc	Compressor startup failure
48	P0	Driver reset protection
49	P5	Compressor phase over-current protection
50	U1	Current detection circuit fault or current sensor fault
51	H7	Compressor out-of-step protection
52	P7	Module temperature sensor circuit failure
53	PU	Capacitor charging failure
54	A1	Outdoor fan IPM module protection
55	Ac	Outdoor fan startup failure
56	AE	Outdoor fan current detection circuit error
57	AJ	Outdoor fan out-of-step protection
58	E0	Indoor fan error

4.3 Unit Maintenance

 WARNING
(1) Only professionals are allowed to carry on daily maintenance.
(2) Before contacting any wire, make sure power is cut off.
(3) Do not let any inflammable objects near the unit.
(4) Do not use organic solvent to clean the air conditioner.
(5) If you need to replace a component, please ask a professional to repair with a component supplied by the original manufacturer so as to ensure the unit's quality.
(6) Improper operation may get the unit broken, hit by electric shock or cause fire.
(7) Do not make the air conditioner wet or electric shock may be lead, ensure that the air conditioner will not be cleaned by water rinsing under any circumstance.
(8) Keep any required vents free of obstructions.
(9) Piping connected to appliances should not contain potential ignition sources;
(10) For appliances using A2L refrigerant connected to one or more rooms via a duct system, the supply and return air should be directly piped to the space. Open areas such as ceilings should not be used as return air ducts;
(11) Precautions should be taken to avoid excessive vibration or pulsation of refrigeration lines;
(12) Protective devices, pipes and fittings should be protected as much as possible to avoid adverse environmental effects, such as the risk of water accumulation and freezing in the overflow pipe, or the risk of pollutants and garbage accumulation;
(13) There should be no expansion and contraction of the pipeline for long-term operation;
(14) The design and installation of the refrigeration system piping should minimize the possibility of hydraulic shock damage to the system;
(15) The solenoid valve should be properly installed in the pipeline to avoid hydraulic shock. Unless sufficient pressure relief is provided, it must not block the liquid refrigerant;
(16) Steel pipes and components shall be protected by rust-resistant coatings to prevent corrosion before contacting any insulating materials;
(17) Electrical components that are not considered as a source of ignition due to compliance with 22.116.1 items B), c), d) or f) may only be replaced with parts specified by the equipment manufacturer. If other parts are used for replacement, leakage will cause ignition of refrigerant;

NOTICE

- | |
|---|
| (1) Before cleaning, please make sure the unit is stopped. Cut the circuit breaker and remove the power socket, otherwise, electric shock may occur. |
| (2) Do not wash the air conditioner with water, otherwise fire hazard or electric shock may occur. |
| (3) When cleaning the filter, please be careful of your steps. If you need to work high above the ground, please be extremely careful. |
| (4) This is not considered an ignition source that needs to be listed. The manufacturer is not responsible for the failure to replace other electrical components that may produce arcing or sparking as specified. |

4.3.1 Heat Exchanger of Outdoor Unit

Conduct cleaning for the heat exchanger of outdoor unit periodically, clean it once at least in every two months. Clean the dust and sundries on the surface of the heat exchanger with dust collector and nylon brush, if there's compressed air source; use the compressed air to blow the dust on the surface of the heat exchanger. Don't use tap water for cleaning.

4.3.2 Drainage Pipe

Periodically check if the drainage pipe is blocked to smooth the condensate water.

4.3.3 Notices at the Beginning of the Using Season

- (1) Check if the air inlet/outlet of the units are blocked.
- (2) Check if the ground connection is reliable.
- (3) Check if the air filter screen is properly installed.
- (4) If starting up again after long-term shut down, preset the power switch of air conditioner to "ON" status before 8h of operation, to preheat the crankcase of outdoor compressor.
- (5) Check if the installation of outdoor unit is firm, if not, please contact with Gree appointed maintenance center.

4.3.4 Maintenance at the End of the Using Season

- (1) Cut off the main power of air conditioner.
- (2) Clean the dust and sundries in outdoor unit.
- (3) If the outdoor unit is rusty, coat the rusty location with paint to prevent it from expanding.

4.3.5 Components Replacement

Components are available in Gree agency or Gree distributors nearby.

4.4 Notice on Maintenance

4.4.1 Information on Servicing

The manual shall contain specific information for service personnel who shall be instructed to undertake the following when servicing an appliance that employs a flammable refrigerant.

4.4.1.1 General Work Area

All maintenance staff and others working in the local area shall be instructed on the nature of work being carried out. Work in confined spaces shall be avoided. The area around the workspace shall be sectioned off. Ensure that the conditions within the area have been made safe by control of flammable material.

4.4.1.2 Checks to the Refrigeration Equipment

Where electrical components are being changed, they shall be fit for the purpose and to the correct specification. At all times the manufacturer's maintenance and service guidelines shall be followed. If in doubt consult the manufacturer's technical department for assistance.

The following checks shall be applied to installations using flammable refrigerants:

- (1) The ventilation machinery and outlets are operating adequately and are not obstructed.
- (2) If an indirect refrigerating circuit is being used, the secondary circuit shall be checked for the presence of refrigerant.
- (3) Marking to the equipment continues to be visible and legible. Markings and signs that are illegible shall be corrected.
- (4) Refrigeration pipe or components are installed in a position where they are unlikely to be exposed to any substance which may corrode refrigerant containing components, unless the components are constructed of materials which are inherently resistant to being corroded or are suitably protected against being so corroded.

4.4.1.3 Checks to Electrical Devices

Repair and maintenance to electrical components shall include initial safety checks and component inspection procedures. If a fault exists that could compromise safety, then no electrical supply shall be connected to the circuit until it is satisfactorily dealt with. If the fault cannot be corrected immediately but it is necessary to continue operation, an adequate temporary solution shall be used. This shall be reported to the owner of the equipment so all parties are advised.

Initial safety checks shall include:

- (1) Those capacitors are discharged: this shall be done in a safe manner to avoid possibility of sparking.
- (2) That no live electrical components and wiring are exposed while charging, recovering or purging the system.
- (3) That there is continuity of earth bonding.

4.4.2 Repairs to Sealed Components

4.4.2.1 Electrical Safety

From the equipment being worked upon prior to any removal of sealed covers, etc. If it is absolutely necessary to have an electrical supply to equipment during servicing, then a permanently operating form of leak detection shall be located at the most critical point to warn of a potentially hazardous situation.

4.4.2.2 Particular Attention

Electrical components, the casing is not altered in such a way that the level of protection is affected. This shall include damage to cables, excessive number of connections, terminals not made to original specification, damage to seals, incorrect fitting of glands, etc.

Ensure that apparatus is mounted securely.

Ensure that seals or sealing materials have not degraded such that they no longer serve the purpose of preventing the ingress of flammable atmospheres. Replacement parts shall be in accordance with the manufacturer's specifications.

NOTICE

The use of silicon sealant may inhibit the effectiveness of some types of leak detection equipment. Intrinsically safe components do not have to be isolated prior to working on them.

4.4.3 Repair to Intrinsically Safe Components

Do not apply any permanent inductive or capacitance loads to the circuit without ensuring that this will not exceed the permissible voltage and current permitted for the equipment in use.

Intrinsically safe components are the only types that can be worked on while live in the presence of a flammable atmosphere. The test apparatus shall be at the correct rating.

Replace components only with parts specified by the manufacturer. Other parts may result in the ignition of refrigerant in the atmosphere from a leak.

4.4.4 Cabling

Check that cabling will not be subject to wear, corrosion, excessive pressure, vibration, sharp edges or any other adverse environmental effects. The check shall also take into account the effects of ageing or continual vibration from sources such as compressors or fans.

4.4.5 Charging Procedures

In addition to conventional charging procedures, the following requirements shall be followed.

- (1) Ensure that contamination of different refrigerants does not occur when using charging equipment. Hoses or lines shall be as short as possible to minimize the amount of refrigerant contained in them.
- (2) Cylinders shall be kept upright.
- (3) Ensure that the refrigeration system is earthed prior to charging the system with refrigerant.
- (4) Label the system when charging is complete (if not already).
- (5) Extreme care shall be taken not to overfill the refrigeration system.
- (6) Prior to recharging the system it shall be pressure tested with OFN. The system shall be leak tested on completion of charging but prior to commissioning. A follow up leak test shall be carried out prior to leaving the site.

4.4.6 Decommissioning

Before carrying out this procedure, it is essential that the technician is completely familiar with the equipment and all its detail. It is recommended good

practice that all refrigerants are recovered safely. Prior to the task being carried out, an oil and refrigerant sample shall be taken in case analysis is required prior to reuse of reclaimed refrigerant. It is essential that electrical power is available before the task is commenced:

- (1) Become familiar with the equipment and its operation.
- (2) Isolate system electrically.
- (3) Before attempting the procedure ensure that:
 - 1) Mechanical handling equipment is available, if required, for handling refrigerant cylinders.
 - 2) All personal protective equipment is available and being used correctly.
 - 3) The recovery process is supervised at all times by a competent person.
 - 4) Recovery equipment and cylinders conform to the appropriate standards.
- (4) Pump down refrigerant system, if possible.
- (5) If a vacuum is not possible, make a manifold so that refrigerant can be removed from various parts of the system.
- (6) Make sure that cylinder is situated on the scales before recovery takes place.
- (7) Start the recovery machine and operate in accordance with manufacturer's instructions.
- (8) Do not overfill cylinders. (No more than 80% volume liquid charge).
- (9) Do not exceed the maximum working pressure of the cylinder, even temporarily.
- (10) When the cylinders have been filled correctly and the process completed, make sure that the cylinders and the equipment are removed from site promptly and all isolation valves on the equipment are closed off.
- (11) Recovered refrigerant shall not be charged into another refrigeration system unless it has been cleaned and checked.

4.4.7 Labelling

Equipment shall be labelled stating that it has been decommissioned and emptied of refrigerant. The label shall be dated and signed.

4.4.8 Recovery

When removing refrigerant from a system, either for servicing or decommissioning, it is recommended good practice that all refrigerants are removed safely.

When transferring refrigerant into cylinders, ensure that only appropriate refrigerant recovery cylinders are employed. Ensure that the correct number of cylinders for holding the total system charge are available. All cylinders to be used are designated for the recovered refrigerant and labelled for that refrigerant (i.e. special cylinders for the recovery of refrigerant).

Cylinders shall be complete with pressure relief valve and associated shut-off valves in good working order.

In addition, a set of calibrated weighing scales shall be available and in good working order. Hoses shall be complete with leak-free disconnect couplings and in good condition. Before using the recovery machine, check that it is in satisfactory working order, has been properly maintained Consult manufacturer if in doubt.

The recovered refrigerant shall be returned to the refrigerant supplier in the correct recovery cylinder, and the relevant Waste Transfer Notice arranged. Do not mix refrigerants in recovery units and especially not in cylinders.

If compressors or compressor oils are to be removed, ensure that they have been evacuated to an acceptable level to make certain that flammable refrigerant does not remain within the lubricant. The evacuation process shall be carried out prior to returning the compressor to the suppliers.

Any quality or other issues encountered in the purchased air conditioner, please contact the local Gree after-sales service department.

5 Qualification of Worker

The manual shall contain specific information about the required qualification of the working personnel for maintenance, service and repair operations. Every working procedure that affects safety means shall only be carried out by competent persons. The training of these procedures is carried out by national training organisations or manufacturers that are accredited to teach the relevant national competency standards that may be set in legislation. The achieved competence should be documented by a certificate.

Examples for such working procedures are:

- (1) Breaking into the refrigerating circuit;
- (2) Opening of sealed components;
- (3) Opening of ventilated enclosures

6 Transportation, Marking and Storage for Units that Employ Flammable Refrigerants

6.1 General

The following information is provided for units that employ FLAMMABLE REFRIGERANTS.

6.2 Transport of Equipment Containing Flammable Refrigerants

Attention is drawn to the fact that additional transportation regulations may exist with respect to equipment containing flammable gas. The maximum number of pieces of equipment or the configuration of the equipment permitted to be transported together will be determined by the applicable transport regulations.

6.3 Marking of Equipment Using Signs

Signs for similar appliances used in a work area are generally addressed by local regulations and give the minimum requirements for the provision of safety and/or health signs for a work location.

All required signs are to be maintained and employers should ensure that employees receive suitable and sufficient instruction and training on the meaning of appropriate safety signs and the actions that need to be taken in connection with these signs.

The effectiveness of signs should not be diminished by too many signs being placed together.

Any pictograms used should be as simple as possible and contain only essential details.

6.4 Disposal of Equipment Using Flammable Refrigerants

See national regulations.

6.5 Storage of Equipment / Appliances

The storage of the appliance should be in accordance with the applicable regulations or instructions, whichever is more stringent.

6.6 Storage of Packed (Unsold) Equipment

Storage package protection should be constructed in such a way that mechanical damage to the equipment inside the package will not cause a leak of the REFRIGERANT CHARGE.

The maximum number of pieces of equipment permitted to be stored together will be determined by local regulations.

7 Information on Servicing

7.1 General

The manual shall contain specific information for service personnel according to 7.2 to 7.10.

7.2 Checks to the Area

Prior to beginning work on systems containing FLAMMABLE REFRIGERANTS, safety checks are necessary to ensure that the risk of ignition is minimised. For repair to the REFRIGERATING SYSTEM, 7.3 to 7.7 shall be completed prior to conducting work on the system.

7.3 Work Procedure

Work shall be undertaken under a controlled procedure so as to minimise the risk of a flammable gas or vapour being present while the work is being performed.

7.4 General Work Area

All maintenance staff and others working in the local area shall be instructed on the nature of work being carried out. Work in confined spaces shall be avoided.

7.5 Checking for Presence of Refrigerant

The area shall be checked with an appropriate refrigerant detector prior to and during work, to ensure the technician is aware of potentially toxic or flammable atmospheres. Ensure that the leak detection equipment being used is suitable for use with all applicable refrigerants, i.e. non-sparking, adequately sealed or intrinsically safe.

7.6 Presence of Fire Extinguisher

If any hot work is to be conducted on the refrigerating equipment or any associated parts, appropriate fire extinguishing equipment shall be available to hand. Have a dry powder or CO₂ fire extinguisher adjacent to the charging area.

7.7 No Ignition Sources

No person carrying out work in relation to a REFRIGERATING SYSTEM which involves exposing any pipe work shall use any sources of ignition in such a manner that it may lead to the risk of fire or explosion. All possible ignition sources, including cigarette smoking, should be kept sufficiently far away from the site of installation, repairing, removing and disposal, during which refrigerant can possibly be released to the surrounding space. Prior to work taking place, the area around the equipment is to be surveyed to make sure that there are no flammable hazards or ignition risks. "No Smoking" signs shall be displayed.

7.8 Ventilated Area

Ensure that the area is in the open or that it is adequately ventilated before breaking into the system or conducting any hot work. A degree of ventilation shall continue during the period that the work is carried out. The ventilation should safely disperse any released refrigerant and preferably expel it externally into the atmosphere.

7.9 Checks to the Refrigerating Equipment

Where electrical components are being changed, they shall be fit for the purpose and to the correct specification. At all times the manufacturer's maintenance and service guidelines shall be followed. If in doubt, consult the manufacturer's technical department for assistance. The following checks shall be applied to installations using FLAMMABLE REFRIGERANTS:

- (1) The actual REFRIGERANT CHARGE is in accordance with the room size within which the refrigerant containing parts are installed;
- (2) The ventilation machinery and outlets are operating adequately and are not obstructed;
- (3) If an indirect refrigerating circuit is being used, the secondary circuit shall be checked for the presence of refrigerant;

- (4) Marking to the equipment continues to be visible and legible. Markings and signs that are illegible shall be corrected;
- (5) Refrigerating pipe or components are installed in a position where they are unlikely to be exposed to any substance which may corrode refrigerant containing components, unless the components are constructed of materials which are inherently resistant to being corroded or are suitably protected against being so corroded.

7.10 Checks to Electrical Devices

Repair and maintenance to electrical components shall include initial safety checks and component inspection procedures. If a fault exists that could compromise safety, then no electrical supply shall be connected to the circuit until it is satisfactorily dealt with. If the fault cannot be corrected immediately but it is necessary to continue operation, an adequate temporary solution shall be used. This shall be reported to the owner of the equipment so all parties are advised. Initial safety checks shall include:

- (1) That capacitors are discharged: this shall be done in a safe manner to avoid possibility of sparking;
- (2) That no live electrical components and wiring are exposed while charging, recovering or purging the system;
- (3) That there is continuity of earth bonding.

WARNING

Only auxiliary devices approved by the appliance manufacturer or declared suitable with the refrigerant shall be installed in connecting ductwork for duct connected appliances, false ceilings or drop ceilings may be used as a return air plenum if a REFRIGERANT DETECTION SYSTEM is provided in the appliance and any external connections are also provided with a sensor immediately below the return air plenum duct joint.

7.11 Pipe Installation

That pipe-work including piping material, pipe routing, and installation shall include protection from physical damage in operation and service, and be in compliance with national and local codes and standards, such as ASHRAE 15, ASHRAE 15.2, IAPMO Uniform Mechanical Code, ICC International Mechanical

Code, or CSA B52. All field joints shall be accessible for inspection prior to being covered or enclosed;

That after completion of field piping for split systems, the field pipework shall be pressure tested with an inert gas and then vacuum tested prior to refrigerant charging, according to the following requirements field-made refrigerant joints indoors shall be tightness tested. The test method shall have a sensitivity of 5 grams per year of refrigerant or better under a pressure of at least 0,25 times the maximum allowable pressure. No leak shall be detected.

The minimum test pressure for the low side of the system shall be the low side design pressure and the minimum test pressure for the high side of the system shall be the high side design pressure, unless the high side of the system, cannot be isolated from the low side of the system in which case the entire system shall be pressure tested to the low side design pressure.

8 Sealed Electrical Components shall be Replaced

9 Intrinsically Safe Components must be Replaced

10 Cabling

Check that cabling will not be subject to wear, corrosion, excessive pressure, vibration, sharp edges or any other adverse environmental effects. The check shall also take into account the effects of aging or continual vibration from sources such as compressors or fans.

11 Detection of Flammable Refrigerants

Under no circumstances shall potential sources of ignition be used in the searching for or detection of refrigerant leaks. A halide torch (or any other detector using a naked flame) shall not be used.

The following leak detection methods are deemed acceptable for all refrigerant systems.

Electronic leak detectors may be used to detect refrigerant leaks but, in the case of FLAMMABLE REFRIGERANTS, the sensitivity may not be adequate, or may need re-calibration. (Detection equipment shall be calibrated in a refrigerant-free area.) Ensure that the detector is not a potential source of ignition and is suitable for the refrigerant used. Leak detection equipment shall be set at a

percentage of the LFL of the refrigerant and shall be calibrated to the refrigerant employed, and the appropriate percentage of gas (25 % maximum) is confirmed.

Leak detection fluids are also suitable for use with most refrigerants but the use of detergents containing chlorine shall be avoided as the chlorine may react with the refrigerant and corrode the copper pipe-work.

NOTE Examples of leak detection fluids are

- (1) Bubble method.
- (2) Fluorescent method agents.

If a leak is suspected, all naked flames shall be removed/extinguished.

If a leakage of refrigerant is found which requires brazing, all of the refrigerant shall be recovered from the system, or isolated (by means of shut off valves) in a part of the system remote from the leak. Removal of refrigerant shall be according to Clause 12.

12 Removal and Evacuation

When breaking into the refrigerant circuit to make repairs-or for any other purpose -conventional procedures shall be used. However, for flammable refrigerants it is important that best practice be followed, since flammability is a consideration. The following procedure shall be adhered to: The refrigerant charge shall be recovered into the correct recovery cylinders if venting is not allowed by local and national codes. For appliances containing flammable refrigerants, the system shall be purged with oxygen-free nitrogen to render the appliance safe for flammable refrigerants. This process might need to be repeated several times.

- safely remove refrigerant following local and national regulations;
 - evacuate;
 - purge the circuit with inert gas (optional for A2L);
 - evacuate (optional for A2L);
 - continuously flush or purge with inert gas when using flame to open circuit;
- and
- open the circuit.

Compressed air or oxygen shall not be used for purging refrigerant systems.

For appliances containing flammable refrigerants, refrigerants purging shall be achieved by breaking the vacuum in the system with oxygen-free nitrogen and continuing to fill until the working pressure is achieved, then venting to atmosphere,

and finally pulling down to a vacuum (optional for A2L). This process shall be repeated until no refrigerant is within the system (optional for A2L). When the final oxygen-free nitrogen charge is used, the system shall be vented down to atmospheric pressure to enable work to take place.

The outlet for the vacuum pump shall not be close to any potential ignition sources, and ventilation shall be available.

13 Charging Procedures

In addition to conventional charging procedures, the following requirements shall be followed.

- (1) Ensure that contamination of different refrigerants does not occur when using charging equipment.
- (2) Hoses or lines shall be as short as possible to minimise the amount of refrigerant contained in them.
- (3) Cylinders shall be kept in an appropriate position according to the instructions.
- (4) Ensure that the REFRIGERATING SYSTEM is earthed prior to charging the system with refrigerant.
- (5) Label the system when charging is complete (if not already).
- (6) Extreme care shall be taken not to overfill the REFRIGERATING SYSTEM.

Prior to recharging the system, it shall be pressure-tested with the appropriate purging gas. The system shall be leak-tested on completion of charging but prior to commissioning. A follow up leak test shall be carried out prior to leaving the site.

14 Decommissioning

Before carrying out this procedure, it is essential that the technician is completely familiar with the equipment and all its detail. It is recommended good practice that all refrigerants are recovered safely.

Prior to the task being carried out, an oil and refrigerant sample shall be taken in case analysis is required prior to re-use of recovered refrigerant. It is essential that electrical power is available before the task is commenced.

- (1) Become familiar with the equipment and its operation) Isolate system electrically.

- (2) Before attempting the procedure, ensure that:
 - 1) Mechanical handling equipment is available, if required, for handling refrigerant cylinders;
 - 2) All personal protective equipment is available and being used correctly;
 - 3) The recovery process is supervised at all times by a competent person;
 - 4) Recovery equipment and cylinders conform to the appropriate standards.
- (3) Pump down refrigerant system, if possible.
- (4) If a vacuum is not possible, make a manifold so that refrigerant can be removed from various parts of the system.
- (5) Make sure that cylinder is situated on the scales before recovery takes place.
- (6) Start the recovery machine and operate in accordance with instructions.
- (7) Do not overfill cylinders (no more than 80 % volume liquid charge).
- (8) Do not exceed the maximum working pressure of the cylinder, even temporarily.
- (9) When the cylinders have been filled correctly and the process completed, make sure that the cylinders and the equipment are removed from site promptly and all isolation valves on the equipment are closed off.
- (10) Recovered refrigerant shall not be charged into another REFRIGERATING SYSTEM unless it has been cleaned and checked.

15 Labelling

Equipment shall be labelled stating that it has been de-commissioned and emptied of refrigerant. The label shall be dated and signed. For appliances containing FLAMMABLE REFRIGERANTS, ensure that there are labels on the equipment stating the equipment contains FLAMMABLE REFRIGERANT.

16 Recovery

When removing refrigerant from a system, either for servicing or decommissioning, it is recommended good practice that all refrigerants are removed safely.

When transferring refrigerant into cylinders, ensure that only appropriate refrigerant recovery cylinders are employed. Ensure that the correct number of cylinders for holding the total system charge is available. All cylinders to be used

are designated for the recovered refrigerant and labelled for that refrigerant (i.e. special cylinders for the recovery of refrigerant). Cylinders shall be complete with pressure-relief valve and associated shut-off valves in good working order. Empty recovery cylinders are evacuated and, if possible, cooled before recovery occurs.

The recovery equipment shall be in good working order with a set of instruction concerning the equipment that is at hand and shall be suitable for the recovery of the flammable refrigerant. If in doubt, the manufacturer should be consulted. In addition, a set of calibrated weighing scales shall be available and in good working order. Hoses shall be complete with leak-free disconnect couplings and in good condition.

The recovered refrigerant shall be processed according to local legislation in the correct recovery cylinder, and the relevant waste transfer note arranged. Do not mix refrigerants in recovery units and especially not in cylinders. If compressors or compressor oils are to be removed, ensure that they have been evacuated to an acceptable level to make certain that flammable refrigerant does not remain within the lubricant. The compressor body shall not be heated by an open flame or other ignition sources to accelerate this process. When oil is drained from a system, it shall be carried out safely.



U.S. CONTACT INFORMATION TRADEWINDS, LLC

E-mail: info@twciimate.com

Contractor Support: 888-850-7928 | Mon-Fri 8 AM - 5 PM EST

GREECOMFORT.COM
