

## EXPLODED VIEW & PARTS LIST



Indoor unit

FXE24HP230V1R32AH

FXE30HP230V1R32AH

FXE36HP230V1R32AH

FXE48HP230V1R32AH

FXE60HP230V1R32AH



Outdoor unit

FXE24HP230V1R32AO

FXE30HP230V1R32AO

FXE36HP230V1R32AO

FXE48HP230V1R32AO

FXE60HP230V1R32AO



# FXE24HP230V1R32AH

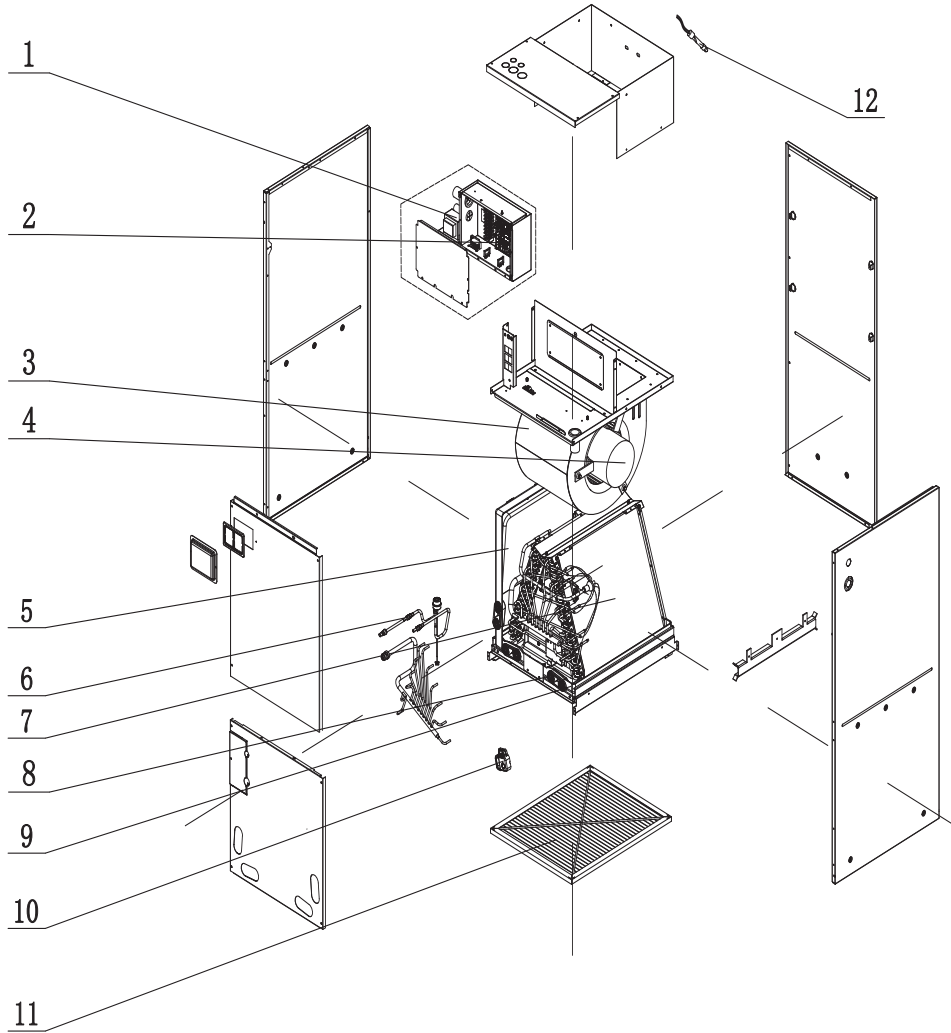

GREE ELECTRIC APPLIANCES INC. OF ZHUHAI  
GREECOMFORT.COM



[Back to main page](#)

## FXE24HP230V1R32AH

No.	Part Description	Qty.	Part Code
NS	Fan retaining plate sub-assy 1	2	01842232
NS	Centrifugal fan assy	1	000052060494
4	Brushless DC Motor	1	15010400001401
3	Centrifugal Fan Housing	1	1570220101
NS	Electronic Expansion Valve	1	072009060083
6	Strainer	2	035021060019
9	Water Tray	1	2690220000102
5	Water Tray	1	2690220000202
8	Choke Plug	8	76718209
NS	Joint	1	06658000008
10	Gas Sensor	1	34002406001501
NS	Electric Expand Valve Fitting	1	4304413269
NS	Sensor Sub-assy	1	390002060708
2	Main Board	1	300002064036
NS	Terminal Board	1	422000060207
NS	Terminal Board	1	42200006005601
1	Transformer	1	43110286
NS	Jumper	1	4202021909
12	Temperature Sensor	1	390001060085
11	Filter Sub-Assy	1	111001060269
NS	insulating board	1	75142201
NS	Packaging Foam	1	110007060322



# FXE24HP230V1R32AO

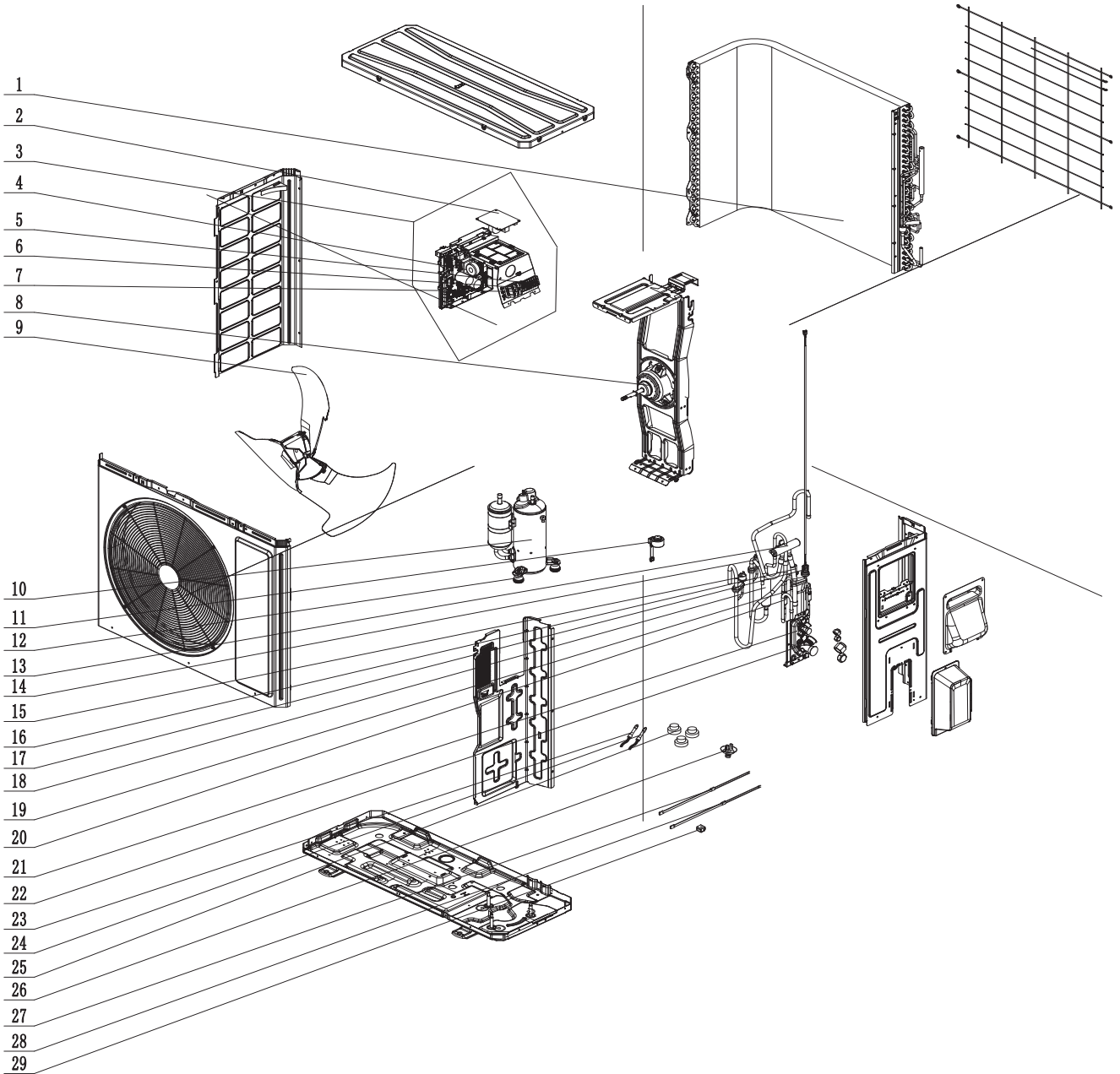

GREE ELECTRIC APPLIANCES INC. OF ZHUHAI  
GREECOMFORT.COM



[Back to main page](#)

# FXE24HP230V1R32AO

No.	Part Description	Qty.	Part Code
NS	Chassis Assy	1	209058060607
28	Electrical Heater (Chassis)	1	7651000413
10	Compressor and Fittings	1	009001061093ST
27	Electrical Heater(Compressor)	1	7651300407
1	Condenser Assy	1	011002062830
21	Cut off Valve	1	070001060035
22	Cut off 3/4(N)	1	070001060033
15	Pressure Protect Switch	1	46020007
17	Pressure Sensor	1	43004406002201
14	Pressure Protect Switch	1	4602000603
16	Electronic Expansion Valve	1	43005017
19	One Way Valve	1	071001060011
11	Electric Expand Valve Fitting	1	4304413216
29	4 Way Valve Coil	1	07201006000605
NS	Motor Support	1	01204806019401
8	Brushless DC Motor	1	150104060094
9	Axial Flow Fan	1	103002060027
NS	Left Side Plate	1	012055060389P01
NS	Right Side Plate	1	01205606043705P03
3	Electric Box Assy	1	100002083767
4	Main Board	1	300027064362
2	Filter Board	1	300020060166
7	Terminal Board	1	42200006001202
6	Terminal Board	1	42200006005601
5	Terminal Board	1	422000060106
NS	Sensor Sub-assy	1	390002060754
NS	Jumper	1	4202021910
NS	Jumper	1	30000300000403
NS	Front Grill	1	01600406001801
NS	Cabinet	1	01202206001901P01
NS	Top Cover Sub-Assy	1	000051060178
NS	Top cover	1	012049060137P01
<b>NS</b>	Rear Grill	1	01600106008701
25	Drainage hole Cap	3	06813401
26	Drainage Joint	1	2611300901



# FXE30HP230V1R32AH

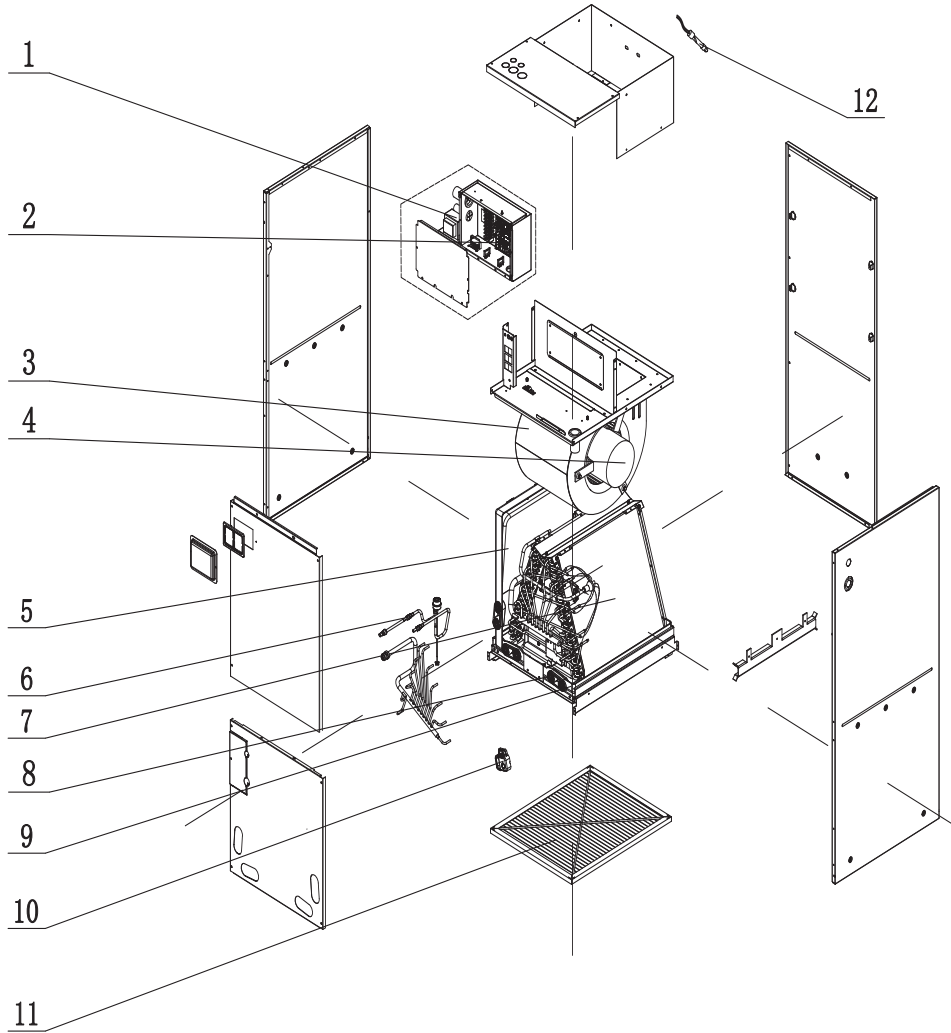

GREE ELECTRIC APPLIANCES INC. OF ZHUHAI  
GREECOMFORT.COM



[Back to main page](#)

## FXE30HP230V1R32AH

No.	Part Description	Qty.	Part Code
NS	Fan retaining plate sub-assy 1	2	01842232
NS	Centrifugal fan assy	1	000052060494
4	Brushless DC Motor	1	15010400001401
3	Centrifugal Fan Housing	1	1570220101
NS	Electronic Expansion Valve	1	072009060083
6	Strainer	2	035021060019
9	Water Tray	1	2690220000102
5	Water Tray	1	2690220000202
8	Choke Plug	8	76718209
NS	Joint	1	06658000008
10	Gas Sensor	1	34002406001501
NS	Electric Expand Valve Fitting	1	4304413269
NS	Sensor Sub-assy	1	390002060708
2	Main Board	1	300002064036
NS	Terminal Board	1	422000060207
NS	Terminal Board	1	42200006005601
1	Transformer	1	43110286
NS	Jumper	1	4202021910
12	Temperature Sensor	1	390001060085
11	Filter Sub-Assy	1	111001060269
NS	insulating board	1	75142201
NS	Packaging Foam	1	110007060322



# FXE30HP230V1R32AO

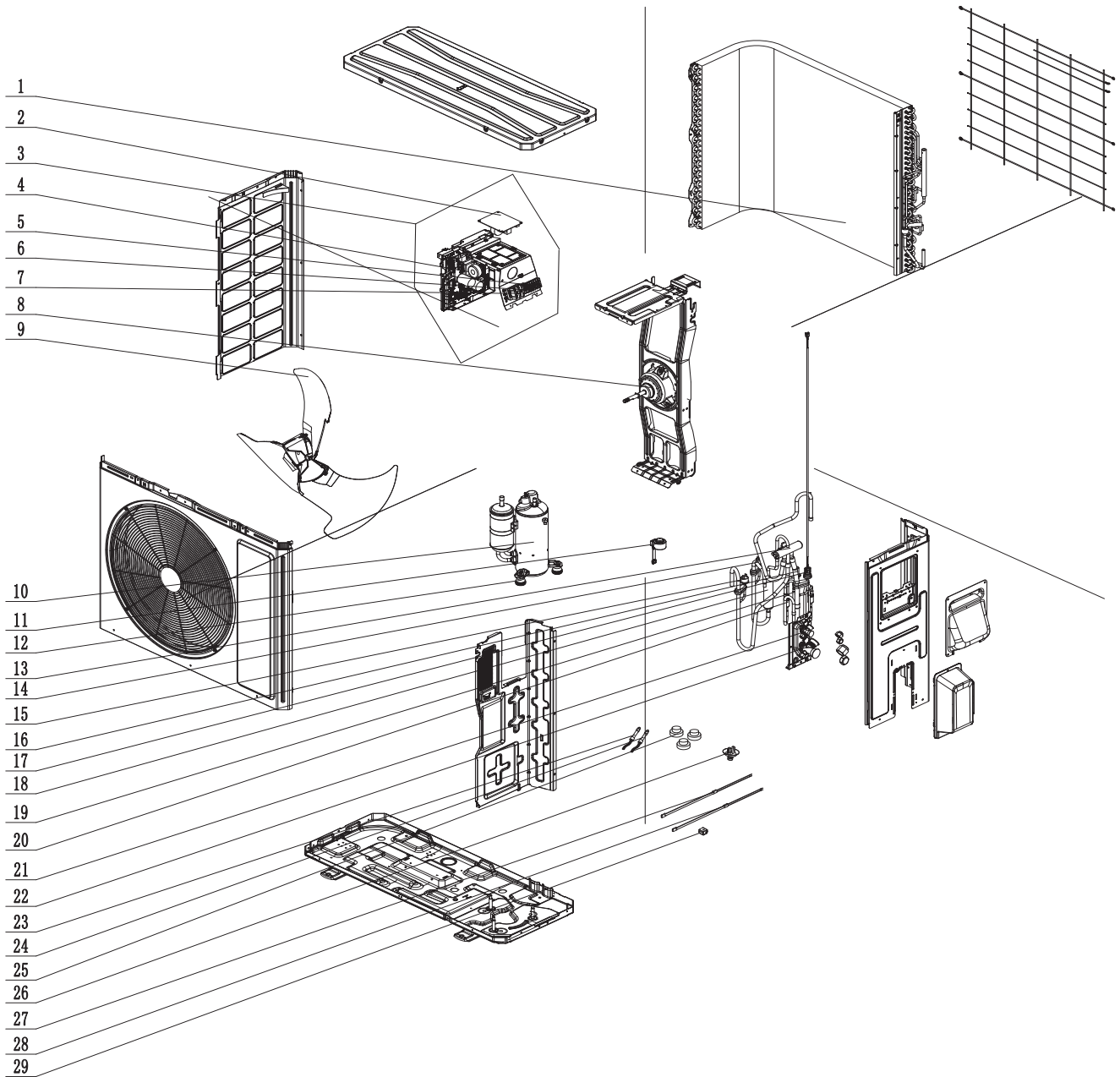

GREE ELECTRIC APPLIANCES INC. OF ZHUHAI  
GREECOMFORT.COM



[Back to main page](#)



# FXE30HP230V1R32AO

No.	Part Description	Qty.	Part Code
NS	Chassis Assy	1	209058060607
28	Electrical Heater (Chassis)	1	7651000413
10	Compressor and Fittings	1	009001061093ST
27	Electrical Heater(Compressor)	1	7651300407
1	Condenser Assy	1	011002062830
21	Cut off Valve	1	070001060035
22	Cut off 3/4(N)	1	070001060033
15	Pressure Protect Switch	1	46020007
17	Pressure Sensor	1	43004406002201
14	Pressure Protect Switch	1	4602000603
16	Electronic Expansion Valve	1	43005017
19	One Way Valve	1	071001060011
11	Electric Expand Valve Fitting	1	4304413216
29	4 Way Valve Coil	1	07201006000605
NS	Motor Support	1	01204806019401
8	Brushless DC Motor	1	150104060094
9	Axial Flow Fan	1	103002060027
NS	Left Side Plate	1	012055060389P01
NS	Right Side Plate	1	01205606043705P03
3	Electric Box Assy	1	100002083767
4	Main Board	1	300027064362
2	Filter Board	1	300020060166
7	Terminal Board	1	42200006001202
6	Terminal Board	1	42200006005601
2	Terminal Board	1	422000060106
NS	Sensor Sub-assy	1	390002060754
NS	Jumper	1	4202021911
NS	Jumper	1	30000300000403
NS	Front Grill	1	01600406001801
NS	Cabinet	1	01202206001901P01
NS	Top Cover Sub-Assy	1	000051060178
NS	Top cover	1	012049060137P01
<b>NS</b>	Rear Grill	1	01600106008701
25	Drainage hole Cap	3	06813401
26	Drainage Joint	1	2611300901



# FXE36HP230V1R32AH

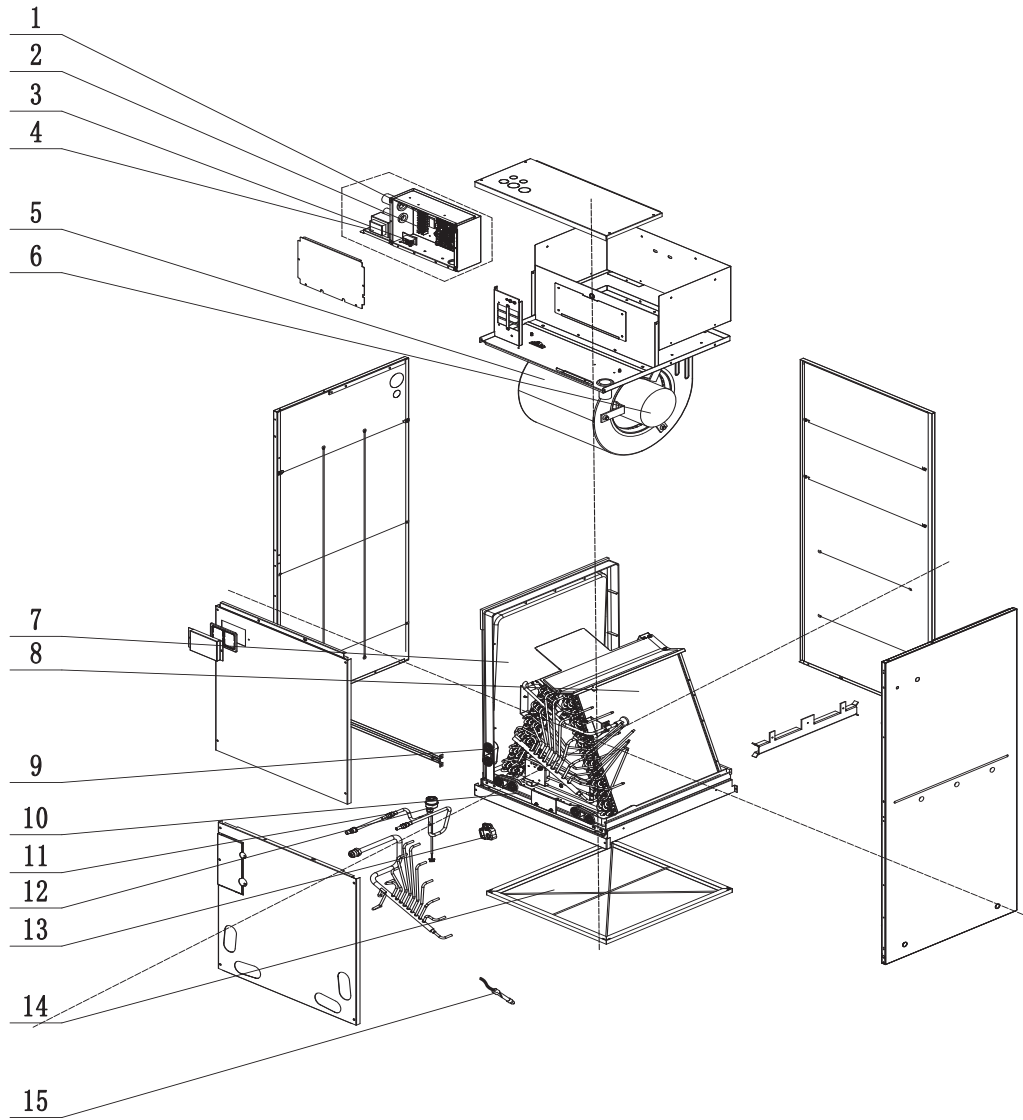

GREE ELECTRIC APPLIANCES INC. OF ZHUHAI  
GREECOMFORT.COM



[Back to main page](#)

## FXE36HP230V1R32AH

No.	Part Description	Qty.	Part Code
NS	Side Plate	1	012010060972
NS	Fan retaining plate sub-assy 1	2	01842232
NS	Centrifugal fan assy	1	000052060415
5	Centrifugal Fan Housing	1	1570220201
6	Brushless DC Motor	1	15010400001401
7	Water Tray	1	2690220402
10	Water Tray	1	2690220502
9	Choke Plug	4	76718209
NS	Joint	1	06658000008
NS	Electric Expand Valve Fitting	1	4304413269
13	Gas Sensor	1	34002406001501
NS	Sensor Sub-assy	1	390002060708
8	Evaporator Assy	1	011001063481P
11	Strainer	2	0721200102
1	Main Board	1	300002064036
2	Terminal Board	1	422000060207
3	Terminal Board	1	42200006005601
4	Transformer	1	43110286
NS	Jumper	1	4202021911
15	Temperature Sensor	1	390001060085
NS	insulating board	1	75142201
14	Filter Sub-Assy	1	111001060160
NS	Packaging Foam	1	110007060322



# FXE36HP230V1R32AO

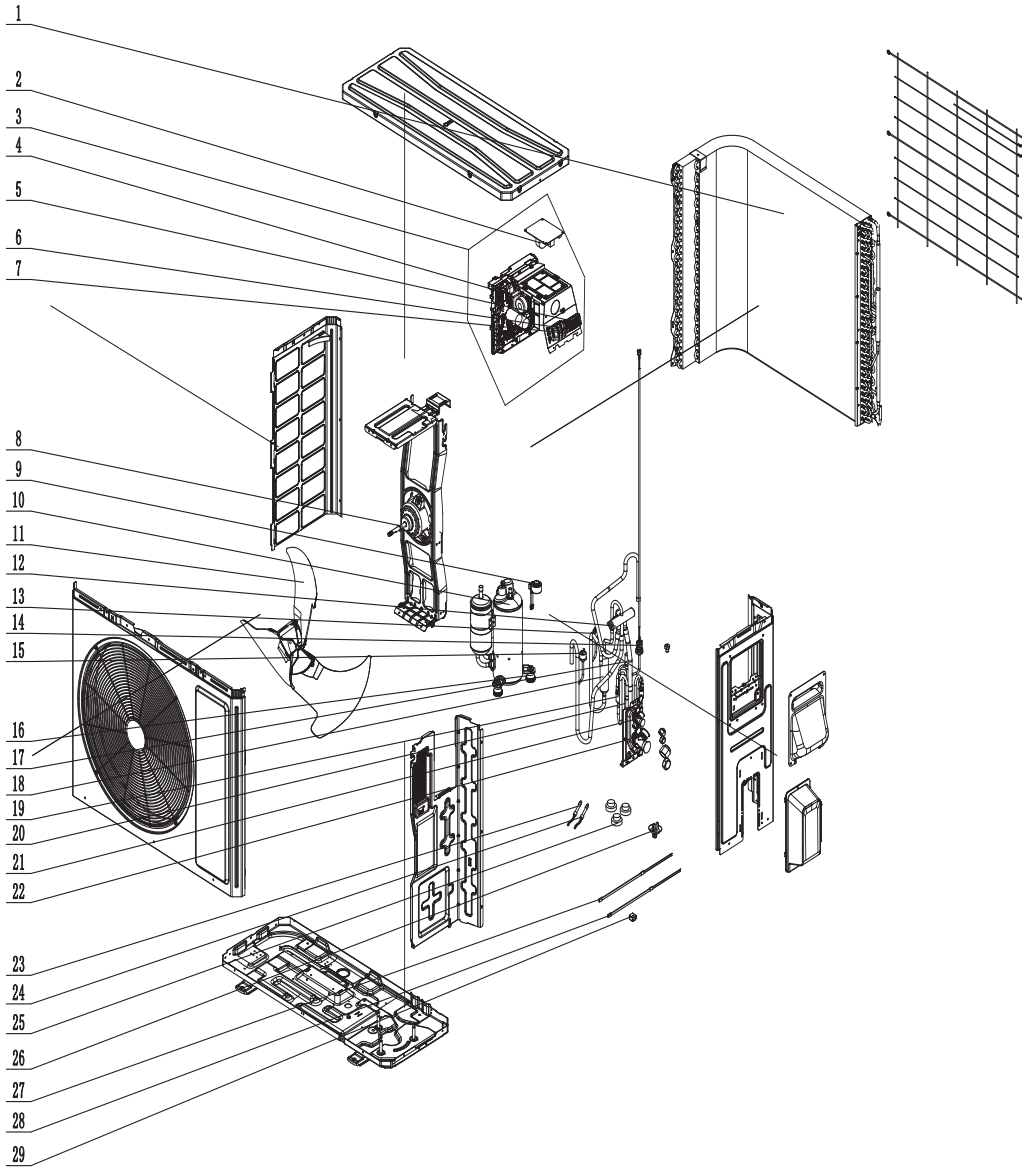

GREE ELECTRIC APPLIANCES INC. OF ZHUHAI  
GREECOMFORT.COM



[Back to main page](#)

# FXE36HP230V1R32AO

No.	Part Description	Qty.	Part Code
NS	Chassis Assy	1	209058060608
28	Electrical Heater (Chassis)	1	7651000413
10	Compressor and Fittings	1	009001061093ST
27	Electrical Heater(Compressor)	1	7651300407
1	Condenser Assy	1	011002062831
21	Cut off Valve	1	070001060035
22	Cut off 3/4(N)	1	070001060033
15	Pressure Protect Switch	1	46020007
14	Pressure Sensor	1	43004406002201
13	Pressure Protect Switch	1	4602000603
17	Electronic Expansion Valve	1	43005017
20	One Way Valve	1	071001060011
9	Electric Expand Valve Fitting	1	4304413216
29	4 Way Valve Coil	1	07201006000605
NS	Motor Support	1	012048060194
8	Brushless DC Motor	1	150104060094
11	Axial Flow Fan	1	103002060027
NS	Left Side Plate	1	012055060389P01
NS	Right Side Plate	1	01205606043705P03
3	Electric Box Assy	1	100002083767
4	Main Board	1	300027064362
2	Filter Board	1	300020060166
7	Terminal Board	1	42200006001202
6	Terminal Board	1	42200006005601
5	Terminal Board	1	422000060106
NS	Sensor Sub-assy	1	390002060754
NS	Jumper	1	4202021912
NS	Jumper	1	30000300000403
NS	Front Grill	1	01600406001801
NS	Cabinet	1	01202206001901P01
NS	Top Cover Sub-Assy	1	000051060178
NS	Top cover	1	012049060137P01
NS	Rear Grill	1	01600106008701
25	Drainage hole Cap	3	06813401
26	Drainage Joint	1	2611300901



# FXE48HP230V1R32AH

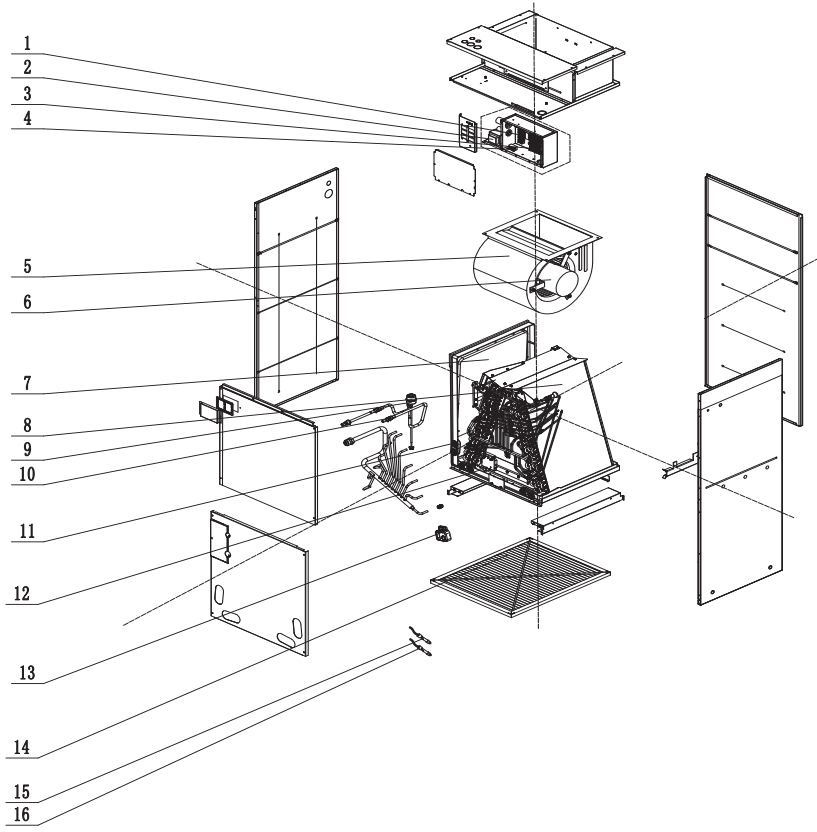

GREE ELECTRIC APPLIANCES INC. OF ZHUHAI  
GREECOMFORT.COM



[Back to main page](#)

# FXE48HP230V1R32AH

No.	Part Description	Qty.	Part Code
NS	Air Scroll	1	012277060111
NS	Fan retaining plate sub-assy 1	2	01842232
NS	Top Cover Sub-Assy	1	000051060202
NS	Top Cover Sub-Assy	1	000051060203
NS	Centrifugal fan assy	1	000052060413
5	Centrifugal Fan Housing	1	1570220301
6	Brushless DC Motor	1	15010400001301
12	Water Tray	1	2690220602
11	Choke Plug	4	76718209
10	Strainer	1	0721200102
7	Water Tray	1	2690220502
NS	Joint	1	06658000008
16	Sensor Sub-assy	1	390002060708
13	Gas Sensor	1	34002406001501
NS	Electric Expand Valve Fitting	1	4304413269
3	Main Board	1	300002064036
1	Terminal Board	1	422000060207
4	Terminal Board	1	42200006005601
2	Transformer	1	43110286
NS	Jumper	1	4202021912
15	Temperature Sensor	1	390001060085
NS	insulating board	1	75142201
14	Filter Sub-Assy	1	111001060188
NS	Packaging Foam	1	110007060360

GREE ELECTRIC APPLIANCES INC. OF ZHUHAI  
GREECOMFORT.COM



[Back to main page](#)

CAT No. 02212025

# FXE48HP230V1R32AO

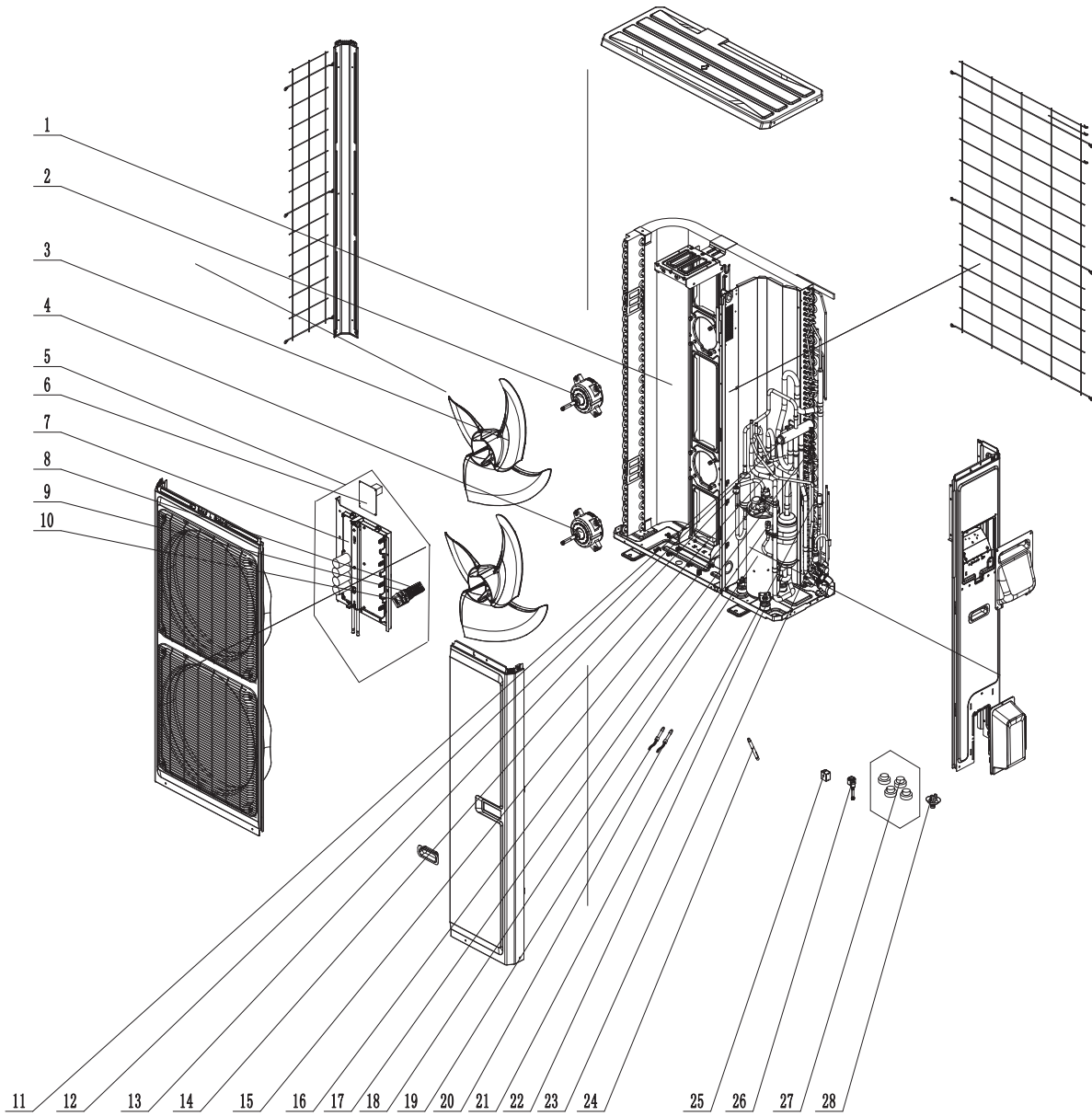

GREE ELECTRIC APPLIANCES INC. OF ZHUHAI  
GREECOMFORT.COM



[Back to main page](#)



## FXE48HP230V1R32AO

No.	Part Description	Qty.	Part Code
NS	Chassis Assy	1	209058060603
NS	Chassis Sub-assy	1	017000061160P
NS	Electrical Heater (Chassis)	1	7651000421
18	Compressor and Fittings	1	009001061089ST
NS	Electrical Heater(Compressor)	1	7651873265
NS	Cut off Valve	1	070001060054
NS	Cut off Valve	1	070001060035
1	Condenser Assy	1	011002062380
2	Brushless DC Motor	1	150104060074
4	Brushless DC Motor	1	15010406007401
NS	Motor Support Sub-Assy	1	017012060451
3	Axial Flow Fan	2	1043410000301
17	fusible plug	1	035222000004
NS	4-Way Valve Assy	1	030152061716
12	4-Way Valve	1	43000338
15	Pressure Protect Switch	1	4602000603
16	Pressure Sensor	1	43004406002204
13	Pressure Protect Switch	1	46020007
14	Gas-liquid Separator	1	035027060043
NS	Joint	1	06652200001
21	Electronic Expansion Valve	1	43005017
23	Strainer	2	035021060018
24	One Way Valve	1	071001060011
25	4 Way Valve Coil	1	07201006000604
26	Electric Expand Valve Fitting	1	4304413297
5	Electric Box Assy	1	100002083768
6	Filter Board	1	300020060144
7	Main Board	1	300027063855
10	Terminal Board	1	42200006001202
8	Terminal Board	1	422000060106
9	Terminal Board	1	42200006005601



# FXE48HP230V1R32AO

No.	Part Description	Qty.	Part Code
NS	Jumper	1	30000300000406
NS	Jumper	1	4202021913
NS	Sensor Sub-assy	1	390002060711
NS	Left Side Plate	1	01205506043501P01
NS	Cabinet Assy	1	000006060262
NS	Cabinet	1	01202206002201P01
NS	Front Grill	2	01600406000201
NS	Right Side Plate Assy	1	000081060413
NS	Top Cover Sub-Assy	1	000051060270
NS	Top cover	1	012049060098P01
NS	Packaging Foam	1	110007060653
28	Drainage hole Cap	4	06813401
27	Drainage Joint	1	26113009



# FXE60HP230V1R32AH

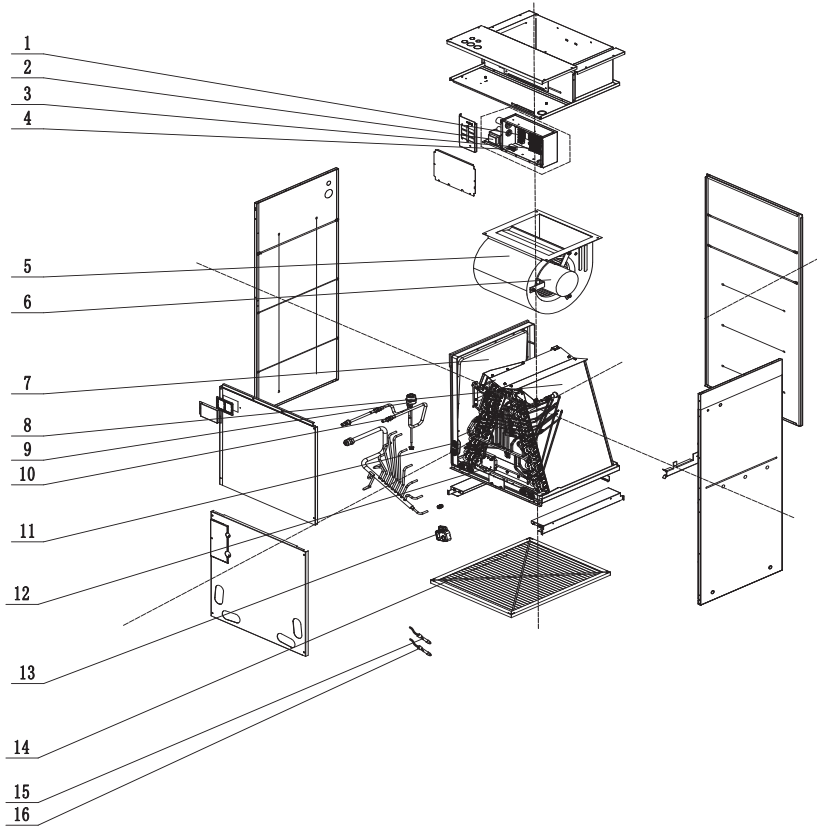

GREE ELECTRIC APPLIANCES INC. OF ZHUHAI  
GREECOMFORT.COM



[Back to main page](#)

# FXE60HP230V1R32AH

No.	Part Description	Qty.	Part Code
NS	Air Scroll	1	012277060111
NS	Fan retaining plate sub-assy 1	2	01842232
NS	Top Cover Sub-Assy	1	000051060202
NS	Top Cover Sub-Assy	1	000051060203
NS	Centrifugal fan assy	1	000052060413
5	Centrifugal Fan Housing	1	1570220301
6	Brushless DC Motor	1	15010400001301
12	Water Tray	1	2690220602
11	Choke Plug	4	76718209
10	Strainer	1	0721200102
7	Water Tray	1	2690220502
NS	Joint	1	06658000008
16	Sensor Sub-assy	1	390002060708
13	Gas Sensor	1	34002406001501
NS	Electric Expand Valve Fitting	1	4304413269
3	Main Board	1	300002064036
1	Terminal Board	1	422000060207
4	Terminal Board	1	42200006005601
2	Transformer	1	43110286
NS	Jumper	1	4202021913
15	Temperature Sensor	1	390001060085
NS	insulating board	1	75142201
14	Filter Sub-Assy	1	111001060188
NS	Packaging Foam	1	110007060360

GREE ELECTRIC APPLIANCES INC. OF ZHUHAI  
GREECOMFORT.COM



[Back to main page](#)

CAT No. 02212025

# FXE60HP230V1R32AO

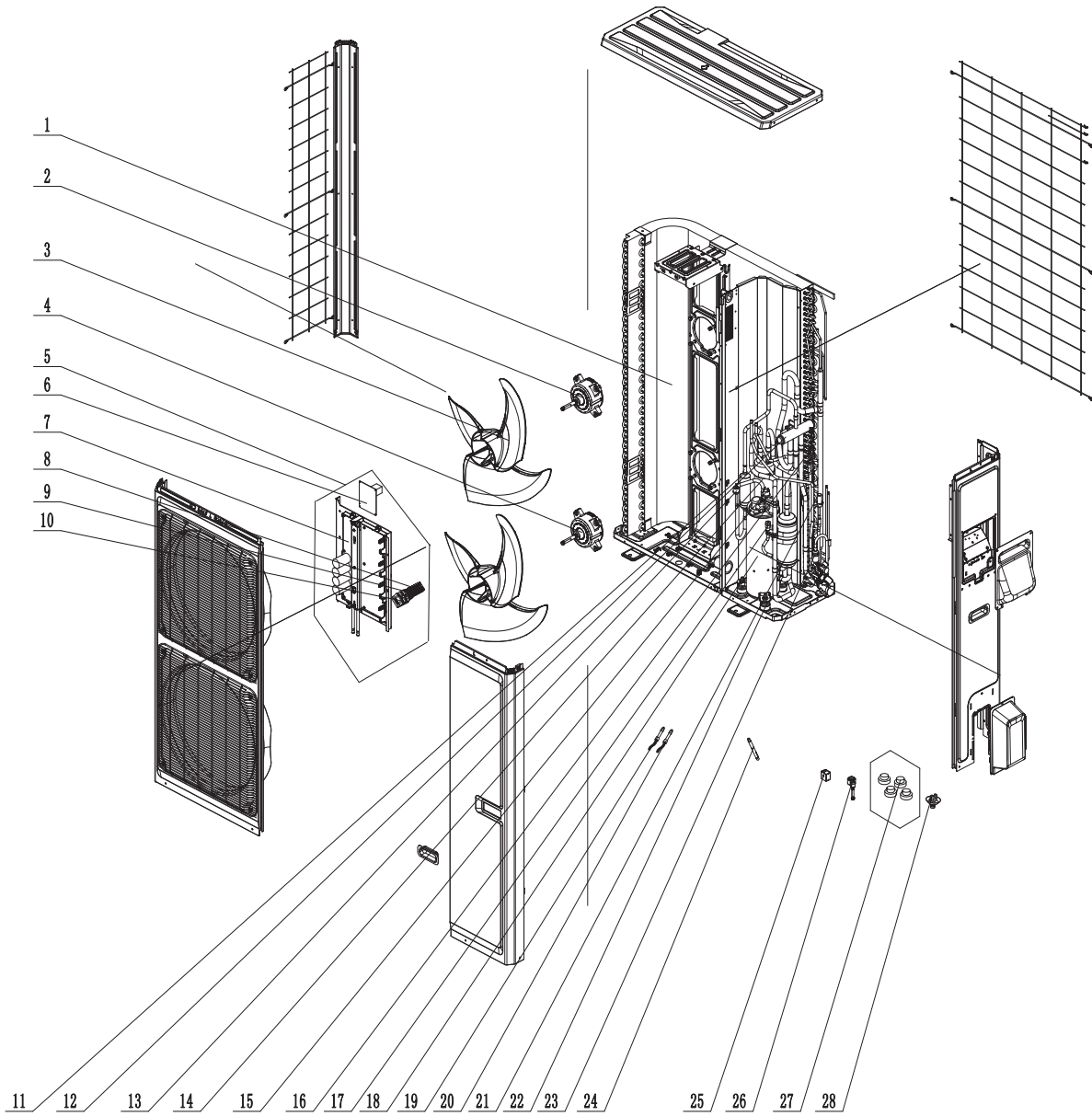

GREE ELECTRIC APPLIANCES INC. OF ZHUHAI  
GREECOMFORT.COM



[Back to main page](#)

## FXE60HP230V1R32AO

No.	Part Description	Qty.	Part Code
NS	Chassis Assy	1	209058060603
NS	Chassis Sub-assy	1	017000061160P
NS	Electrical Heater (Chassis)	1	7651000421
18	Compressor and Fittings	1	009001061089ST
NS	Electrical Heater(Compressor)	1	7651873265
NS	Cut off Valve	1	070001060054
NS	Cut off Valve	1	070001060035
1	Condenser Assy	1	011002062380
2	Brushless DC Motor	1	150104060074
4	Brushless DC Motor	1	15010406007401
NS	Motor Support Sub-Assy	1	017012060451
3	Axial Flow Fan	2	1043410000301
17	fusible plug	1	035222000004
NS	4-Way Valve Assy	1	030152061716
12	4-Way Valve	1	43000338
15	Pressure Protect Switch	1	4602000603
16	Pressure Sensor	1	43004406002204
13	Pressure Protect Switch	1	46020007
14	Gas-liquid Separator	1	035027060043
NS	Joint	1	06652200001
21	Electronic Expansion Valve	1	43005017
23	Strainer	2	035021060018
24	One Way Valve	1	071001060011
25	4 Way Valve Coil	1	07201006000604
26	Electric Expand Valve Fitting	1	4304413297
5	Electric Box Assy	1	100002083768
6	Filter Board	1	300020060144
7	Main Board	1	300027063855
10	Terminal Board	1	42200006001202
8	Terminal Board	1	422000060106
9	Terminal Board	1	42200006005601



# FXE60HP230V1R32AO

No.	Part Description	Qty.	Part Code
NS	Jumper	1	30000300000406
NS	Jumper	1	4202021914
NS	Sensor Sub-assy	1	390002060711
NS	Left Side Plate	1	01205506043501P01
NS	Cabinet Assy	1	000006060262
NS	Cabinet	1	01202206002201P01
NS	Front Grill	2	01600406000201
NS	Right Side Plate Assy	1	000081060413
NS	Top Cover Sub-Assy	1	000051060270
NS	Top cover	1	012049060098P01
NS	Packaging Foam	1	110007060653
28	Drainage hole Cap	4	06813401
27	Drainage Joint	1	26113009

